

# Emergency and Safety Equipment India Special Edition 2021



**SPENCER** india







## SPENCER 360° EMERGENCY SOLUTIONS

Since 1989 Spencer has been designing solutions for emergency.

Our range features over 1,700 products including transport systems, solutions for immobilization, devices for resuscitation, suction and oxygen therapy, a wide assortment of bags and backpacks and a vast catalogue dedicated to personal equipment for paramedics and medical staff.

## QUALITY IS OUR SPECIALTY

A high orientation towards the quality of products and services offered, has always characterized Spencer, that throughout twenty-five years of experience, has become a consolidated brand leader in the emergency market.

The function, the security, the durability and the performance of our products are the foundations of our activity. Spencer is aiming to increase the standard quality in the rescue supplying field and at the same time satisfy the expectations of those who work in the front line of emergency.

Spencer has based its company's order upon two important strategy factors: certification of Quality Management System in compliance not only to the EN ISO 9001:2008 but also to the specialised standards regarding medical devices

EN ISO 13485:2012, issued by T V S D Product Service GmbH, Germany.



## SPENCER INDIA TECHNOLOGIES PVT LTD

**Spencer India Technologies Pvt Ltd** is an integral part of Spencer Italia S.r.l, based in Italy and leader in the manufacturing **Emergency care medical devices and ambulance equipments** with wide range of products which are available in India.

Spencer India is a fast growing company, known as leading supplier for medical equipment, emergency care devices, ambulances, rescue, disaster management, fire & safety, transportation, evacuation, water rescue & military.

Spencer India was established in 2011 headquartered in New Delhi. We are an ISO 9001:2008 and ISO 13485 certified company.

We have a PAN India presence and operates in various states all over the country.

Spencer equipments are used in ambulances, private & govt hospitals, nursing homes, defense, research institutes & centers, corporate houses, rescue & disaster, specialized patient vehicle, in international and national sports events, governmental organizations and disaster management activities all over India. Spencer also provides "Free of Cost" training to various ambulance paramedics and training to handle evacuations in case of fire and disaster situations all over India.

Moreover we carry on special projects for handling any emergency in schools and airports and safety program in corporate organizations and industries.

**We sincerely hope at Spencer, we will simplify dimensions for you.**

## SPENCER SUPPORT

At Spencer we believe in excellence in everything we do and being "best". This mindset has led spencer India to win multiple opportunities and excellence among the customers.

We aspire to continue and bring many such "global standards" and inculcate "best practices" in all our services in Indian Healthcare environment.

In this term we intend to emerge as the best business platform centre for our business partners & customers.

Spencer India has already an international level sales & service centre in India for our customer needs and requirements, with showrooms in many regions of India. We have also established an international footprint for learning & training emergency care frontiers in India.





## A LEGACY OF SERVICE AND CORPORATE SOCIAL RESPONSIBILITY

Spencer is differentiated through an unmatched culture of uncompromising ethics and service to others. Healthcare is not just a “business” but a vehicle to “make a difference” and create a better world for everyone.

As CSR projects we deliver free products, services, training and devices to different NGOs, Charitable trust, Free Ambulance services, to companies like Rotary club, PFA, Khushi.

## SPENCER PROJECT TEAM

Particular emergency requirements need customized answers. In order to be closer to our customers we have created SPT - Spencer Project Team. A team of professionals and technicians that can verify and design a product that meets the customer's specific requirements and ideas. The result is a unique product that will not disappoint expectations. We believe that people's ideas deserve attention and space.

## SALES SERVICE

We are aware that we are successful by not just having high quality products, but we also match them with a high level of assistance. First of all, efficient communication is guaranteed, hence our personnel is available among all major cities in India and is able to answer, satisfy any sales, technical or logistic requirements.

## CUSTOMER CARE

Following our products after they have been sold, customers' feedback become a very important resource to continue improving our services and is regularly practiced at our customer care centre in New Delhi. It has allowed our company to reach a high level of professionalism, recognized by our customers.





## TRANSPORT SYSTEMS

Spencer, a solid and continuously growing company, active in the entire world, intends to confirm its experimental vocation. Spencer is a company that is capable of generating new solutions for transport, always on the lookout for new trends in design to subvert the established order in the rescue field. The section dedicated to stretchers illustrates some of the most significant qualities of contemporary engineering design.



# GENERAL CHARACTERISTICS

## TWIST EFFECT

Twist is Spencer's new point of view with regards to stretchers of a superior class.

Twist was created to fill a gap in the category of self loading stretchers; that of a scarce manoeuvrability due to the use of only two pivoting wheels.

When an increased manoeuvrability of the stretcher is required, the activating of a lever will enable the fixed front wheels of the trolley to rotate freely and by simply letting go of the lever, return the wheels to their natural state.

Spencer, always looking to improve the working conditions for operators, has, with Twist, introduced a system that optimises manoeuvrability and reduces the strain on the lumbar region which can be caused every time that it is necessary to change direction.

The Twist system can be requested for the Cross, Carrera, Alto and Fox stretchers.



## COMPLIANCE SUSPENSION EFFECT

Spencer has developed a new concept of suspension; the SCS system (Spencer Compliance Suspension), that represents an important step forward in the field of passive suspension construction. SCS differentiates itself from the traditional approach by the way in which it generates movement of the suspension under load. In fact, it uses a simple arm with particular properties of rigidity which allow the arm itself to guarantee its traditional structural role and also to make an important contribution to the movement of the suspension when under load. No matter what the kind of surface, the special curved shaping of the legs modify immediately the softening effect of each wheel. The result of this integration of functions is a system that can guarantee a high level of comfort and safety without the complexities and high costs normally associated with an equivalent performance.

Among the improved characteristics, the most significant is the lengthwise flexibility of the suspension, which is fundamental in the creation of high levels of comfort.



## ERGONOMIC DESIGN

We believe that good design must begin with a full understanding of the function of a product. This, for us, means taking into consideration the simple operations of opening, closing, clamping, adjusting or transferring and then analysing each separate element with regards to the operators interaction with the stretcher. We study these elements therefore, not only to have an aesthetically pleasing appearance and a comfortable grip but also to render the operators work easier when using our stretchers. This can be seen by now taking a closer look at the instruments used for manoeuvring.



## GENERAL CHARACTERISTICS

### SELF EFFECT

The Self system allows for the transportation of the load (patient) without the usual risk of injury that an operator can face during the lifting phase. It completely sustains loading or unloading, onto or off the ambulance. The inferior part of the stretcher has an articulation that during closure can be activated, not by a lifting movement but, by a simple pushing action.

With this, the wheels with which it is equipped are easily brought into contact with the surface onto which it has to be loaded. The advantage of this system is that the load can be made to slide without any extra effort.

This system therefore on one hand eliminates any risk of strain on the lumbar region of the operator and on the other, in its role as a trolley, presents itself as highly stable and easy to handle.

All this is due to the well balanced structure and a notable smoothness when in motion.

The wheels have a diameter of 200 mm which also contribute to the quality of this stretcher.

This has all been achieved while maintaining a low weight and perfect balance.



### CRASH-ASSIST

Always looking for solutions for the most extreme of cases, Spencer has improved absorption still further with Crash-assist.

Centre of gravity shifted, compensated piston, auxiliary framework. Result: only 190 mm drop range.



### SILENCE

The silence of the gears is accentuated and therefore appreciated during ambulance transportation, when the care of the patient calls for great concentration.

The insertion of a self-oiling system in nylon between the metallic parts ensures continuous silence and durability.

What is very impressive is the total absence of vibration, maintained balance and deadening of any noise even when used on roads.







## WHEELS

Wheels with a diameter of 200 mm offer increased smoothness without requiring extra effort.

Wheels forged in an extremely light and elastic copolymer, that glide on precision ball-bearing pads of rubberised “soft” polyurethane.

The adoption of spherical pads for both the pivoting of the supports and the rotating axis of the wheels, along with the use of an elasticised rubber covering, contributes considerably to the reduction of noise even on uneven surfaces.

The elasticity of the polyurethane covering, guarantees maximum comfort since, thanks to the high shock absorption capacity, absorbs irregularities of the ground thus avoiding the transmission of any vibrations or jolting to the stretcher.

The design of the outrunner assures silence and a perfect adherence to the ground. The special technique used in the making of the ring, gives concentricity without ovalization thus guaranteeing a uniform rotation.

## WELDED FRAMEWORK

The rigid upper framework, but above all the fork on the rear, are examples of the creativity and inventiveness that have always been freely used at Spencer, right from the beginning of its young yet intense story. The structure does in fact, show a pronounced curvature. The pleasing appearance is gratifying but even more so, is that of when it is actually in motion, thanks to the conception of a chassis that can confront any kind of surface. As we descend taking a look at more of the details, we note that apart from having a curved line, the tubes have section for the height variations and are also welded with the appropriate techniques. To be honest, it is difficult to separate the aesthetic ideas and the structural necessities of such products. The importance is to underline that the welded frameworks have been judged to be light, rigid, versatile, durable and exceptionally trustworthy.

## BRAKES

An integrated braking system allows the trolley to remain stationary on slopes, easy steering and the blocking of the trolley in the desired position. The procedure of braking, made easier by the use of a wide pedal, is gentle, requires no extra effort or regulation and simultaneously blocks both wheel and support.

## PAINTWORK

With the powder paintwork, a method which produces few harmful residues and is therefore very ecological, we have moved into a new field for the stretcher industry. The results attained are a demonstration of just how much we have discovered and learnt in this particular field: total elimination of solvents, an almost complete elimination of waste fluids and an overall waste quota of less than 5%; all of which permit the realisation of a product of a superior quality than that possible when employing traditional methods.

## HD-K FUNCTIONAL DESIGN

It seems that the world today is running towards ever more complex schemes, far away from every-day utility. The new HD-K directional system proposes a new style which embraces innovation and simplicity without loss of technological complicity: synthetic harmony between essential style and interactive mechanics. Spencer delivers a new way of interpreting complicity and advanced technological solutions, offering a new generation of integrated systems for directional systems which at first glance will immediately surprise you. The aggressive and reassuring lines allow immediate recognition of the charismatic profile of the Spencer HD-K inspired by the ultimate functionality and the continuous research of synthesis between ergonomics, refined beauty and care for details.

The support is predisposed for the installation of the new Track 10 infusion bottle holder

The grip handle can be operated even if the operator has working gloves on; to guarantee operation in any situation

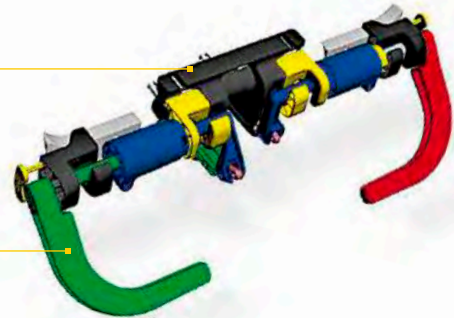

The compensation of the lifting movement during the entire vertical excursion has been obtained with a patented, extremely compact counter-balance mechanism, based on the combined compression of various elastic elements commanded by an ergonomically shaped grip handle.

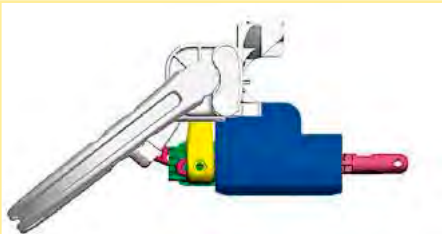

The blocking system, totally manufactured in auto lubricating thermoplastic, is situated in the upper part: it is very easy to use and thanks its colour, easy to identify.

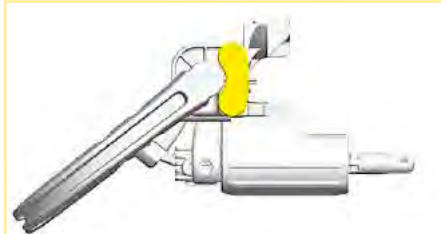

The profile has a truncated ellipse shape offering a large contact-surface; the shortening allows a more comfortable grip and reduces the risk of hand slipping.

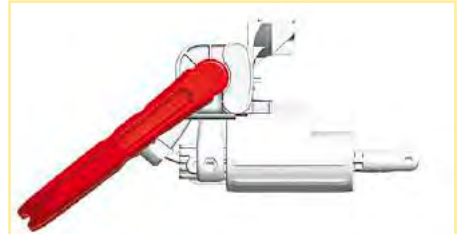



## CROSS ROLL-IN STRETCHER TROLLEY, ADJUSTABLE HEIGHTS

The Cross stretcher is supplied with two straps model STX 702.

The importance of a patient's calm and positive psychological attitude is recognised as one of the key factors for good results for the rescue and transport. The Spencer team, manufacturers of rescue and patient transport devices, has dedicated special attention to the relationship between the patient and the stretcher, the patient and the operator and the operator and the stretcher. Everything in order to realise an ergonomically viable product even in uncomfortable physical, psychological and environmental conditions, achieving success even in the most intense operative situations. Cross' secret lies in the Space Frame concept, which through the welding of special tube, made of stainless steel and aluminium, produces a truly innovative structure, not only in shape and functionality, but also and above all in the intrinsic technological contents and in the research of space usually unused. We have also tried to give these stretchers an aesthetic and distinctive look.

The possibility to have a vast choice of colours increases the possibility of linking/combination, to which special customisations can be added for adequate quantities.

An ample radius separates the two volumes of the body in order to supply a better grip for the fingers, while the palm is placed on a curved surface: this device makes the grip more comfortable and prevents the hands from slipping

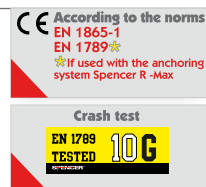

### TECHNICAL DATA

- Length 1970 mm
- Shortened length 1650 mm
- Width 570 mm
- Weight 45 kg
- Load capacity 170 kg
- Wheels 200 mm, front fixed, rear autodirectional
- Brakes posterior
- Loading height from 520 to 750 mm
- Reclining sidebars
- Length 680 mm
- Height 200 mm

# CROSS CHAIR

## STRETCHER/TRANSPORT CHAIR

The Cross Chair stretcher is supplied with two model STX 702 restraint straps and mattress.

Cross Chair is the ideal device to assist those rescue professionals who in their daily activities wish to experience a really new solution that improves emergency road rescue and transport with the emergency vehicle.

Cross Chair can be used as a stretcher or as a transport chair as it adapts to a wide range of operational scenarios.

Two essential devices rolled into one big project.

### CONFIGURATIONS

Cross Chair offers an extraordinary versatility without comparison. The adjustment mechanism allows instant adaption of the device to the requirements of the intervention.

The change of configuration takes only two seconds.



The Safe Bar reclining armrests restrain the patient also in transport chair configuration

Telescopic handles



CE According to the norms  
EN 1865-1  
EN 1789\*  
\*If used with the anchoring system Spencer R -Max

Crash test

EN 1789  
TESTED  
10G

### TECHNICAL DATA

#### Trolley

- Length 1980 ± 10 mm
- Width 570 ± 5 mm
- Wheels ø 200 mm

- Weight 35,5 ± 0,5 kg
- Loading capacity 150 kg

#### Stretcher/ Chair

- Height (CM) 1430 mm
- Width (CM/SM) 600 mm
- Loading capacity 150 kg

# CARRERA ROLL-IN COT

The Carrera stretcher is supplied with two straps model STX 702.

Here comes the new Carrera, a wholesome and solid stretcher, able to rewrite the parameters of excellence for its category.

No one before has ever given such care and attention to technological innovation and exploitation of space.

No other cot has a design as harmonious and no other cot is able to contain a spinal board.

Two versions, tall and short, designed, developed and constructed entirely in Europe to satisfy all the needs of those who in the rescue field, are used to high standards.

The lateral sidebars swivel at a 180 ° angle and disappear from sight, the opening mechanism is integrated in the sidebar itself to avoid jamming



CE According to the norms  
EN 1865-1  
EN 1789\*  
\*If used with the anchoring system Spencer R -Max

Crash test

EN 1789  
TESTED 10G  
SPENCER

Crash-assist system to assure safety during loading and unloading procedures

## TECHNICAL DATA

### Carrera Tec

- Length 1970 mm
- Width:570 mm
- Weight 38 kg
- Load capacity 170 kg
- Brakes posterior
- Loading height low loading version from 450 to 590 mm
- Loading height high loading version from 550 to 690 mm

### Carrera Activ

- Length 1970 mm
- Shortened length 1620 mm
- Width 570 mm
- Weight 36 kg
- Load capacity 170 kg
- Loading height low loading version from 450 to 590 mm
- Loading height high loading version from 550 to 690 mm

### Carrera Pro

- Length 1970 mm
- Width 570 mm
- Weight 38 kg
- Load capacity 170 kg
- Loading height low loading version from 500 to 650 mm
- Loading height high loading version from 590 to 740 mm



## TEC TROLLEY FOR INCUBATOR

The trolley is designed to support incubators of different sizes, thanks to an adjustable fastening system. The cart is equipped with an integrated stainless steel support surface 520 x 450mm. 10G Certified if used with the fastening system R-max (ST42702).

The manoeuvring handles are positioned in a rational and unambiguous way; thanks to their particular form they adapt to the anatomy of the hand and the long slide way makes it impossible to accidentally activate them



Brakes on the rolling movement and on the axis

### TECHNICAL DATA

- Length 1980 mm
- Width 580 mm
- Weight 32 kg
- Load capacity 170 kg
- Wheels 200 mm
- Brakes posterior
- Table dimensions 520x450 mm
- Table height (From main frame) 190 mm
- Incubator supports distance From 250 to 800mm
- The distance between incubator supports is adjustable in order to adapt to your own incubator

**Tec Trolley for incubator**

**CA60023C**

## STRETCHER FIXATION SYSTEMS

The choice of the correct fixation system for transport devices like auto loading, fixed or semi-automatic stretchers, is one of the most delicate phases during the construction of an ambulance. In fact the wrong choice can cause a lot of inconvenience and damage which can cause serious repercussions.

The loading capacity of a fixation system is determined by many different parameters.

The direction of the load (traction load,

cutting load or combined) has a high influence on the effects of these parameters and the performance of a fixation device is determined by their combination.

Our research has developed in this direction and has generated great effectiveness and safety. Spencer's fixation systems offer an almost unlimited choice of solutions which allow efficient and effective management of any possible problem.



**FP**

### POSTERIOR FIXATION

Posterior fixation system for ambulance stretchers. Made out of highly resistant vermicular graphite it is composed of two elements: a base which must be fixed directly to the loading platform and a mobile part which allows the fixation of the actual stretcher.

In order to make it compatible with all models, it is supplied with two sizes of fixation elements.

**FP**

**ST42100A**



**FA**

### ANTERIOR FIXATION

Anterior fixation system for ambulance stretchers. Manufactured in stainless steel and composed of two elements: a traverse frontal fixation which limits the movements of the stretcher and an adjustable guide which optimizes the loading operation and laterally stabilizes the stretcher.

Easy to install it can be used with all self-loading Spencer stretchers.

**FA**

**ST42200A**

## SPENCER 10 G SYSTEMS

### Test Center

At a first glance, the goal seems to be ambitious but the Spencer Test Center has the objective of soon becoming one of the international points of reference, for agencies, emergency-related associations as well as companies who wish to test their own products, systems and accessories.

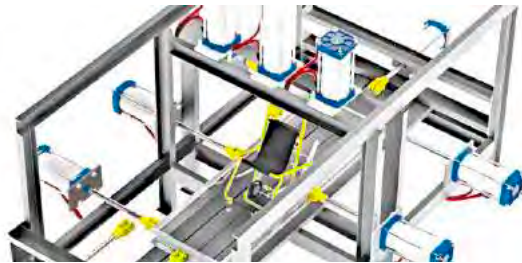

Even those with a high technological level. In fact, we believe that, in order to remain the leader of a rapidly evolving market, the best way is integration. Integration not only within our own company, but also in a more wide and extended way towards suppliers and partners. Spencer boasts a complete department with highly professional staff dedicated to testing and simulation procedures of our own products and systems.

The department is equipped with a complete range of machines and systems able to evaluate static and dynamic crash tests, vibrations, static loading, repeatability, pressure areas.

These, together with other testing apparatus, confer to our products the same quality that the star in our logo deserves.

### Fixation systems

The safety of an ambulance is measured by the capacity to integrate various solutions in perfect harmony and synergy. In both computer simulations and under actual testing, the fixation systems have been tested and optimized in terms of crash behaviour, robustness, rigidity as well as resistance to bending and torsion.



Our engineers have performed various tests of frontal, asymmetrical, lateral and posterior collision, three-meter fall and rollover tests in accordance with both the strict Spencer protocols and the EN 1789 norms.

The various individual fixing systems underlined by the rich assortment of pre-tensioned restraints, compressed gas bottle containers, of medical devices or of simple back packs, have been tested according to strict standards and developed side by side with leading suppliers in order to guarantee state-of-art protection on ambulances equipped with Spencer fixation systems.

Strict tests that allow your fixations and equipment to perform their every-day job with maximum serenity.



## STRETCHER

### 10 G FIXATION SYSTEMS



#### R-MAX

##### 10 G FIXATION SYSTEM

It is the fixation system for stretchers certified 10 G in conformity with the technical regulations EN 1865 and EN1789. The hook on the front part is formed of a lever system that locks on contact with the front pin of the stretcher.

R-Max

ST42702C



#### SHARP

##### 10 G RAPID UN-LOCKING SYSTEM FOR SELF LOADING STRETCHERS

Sharp is an innovative system and now the operator can quickly download the stretcher from the ambulance loading platform with just one movement. The yellow colour of the handle coated in glass reinforced nylon, makes immediate identification simple. The operator no longer has to put his hands below the stretcher frame to unhook it from the fixing system so the risk of injuries is avoided and operating time is reduced. Sharp has to be used with the S-Max Sharp fastening system.

SHARP

CR00025B



#### S-MAX

##### 10G FASTENER FOR STRETCHER

Fastener for 10g certified stretchers, created to ensure their safe anchorage inside medical vehicles.

S-Max

ST42707B

## BELTS FOR STRETCHERS AND PAEDIATRIC RESTRAINT SYSTEM

From the onset the challenge has been to overcome the boundaries of space and the limitations of the belts in order to meet the daily needs of stretchers in every part of the world.

The answer to this challenge is in the DNA Strap. Here we have a retractable belt that is an optional for all Spencer products that are equipped with the DNA system.



### DNA STRAP

#### BELT WITH INTEGRATED RE-WINDING SYSTEM

The winding system, which contains a sector of the belt, is housed within the lining of the patient board in the backrest of the seat or the body of the spinal board. Thanks to tension and to a simple kinetic mechanism the belt is easily extracted for use. This is the best way to always have at hand the patient restraints and to automatically store them without having to worry about any obstruction during transfer. Discover our innovative range of DNA Strap safety belts, that distinguish themselves for the wide choice of style, extraordinary flexibility in use, versatility in adaptation to differing builds and a very new conception of storage along with all the traditional characteristics of the Spencer belts.

**DNA STRAP**

**ST00497B**



### DNA STRAP THORACIC

#### BELT WITH INTEGRATED RE-WINDING SYSTEM

Chest harness with retractor system for Spencer stretchers fitted with DNA patient board.

**DNA STRAP THORACIC**

**ST00498B**



### FIXO KID

#### PAEDIATRIC RESTRAINT SYSTEM

To meet all the needs of the rescuers, we have designed and manufactured a product essential for the safety of paediatric patients. Fixo Kid is characterized by adjustable and easy to use restraining belts, easy to clean materials, lightness, strength and low storage size. All these features are extremely important for this kind of devices. It is supplied in a bag for transport and storage.

Length extended 800 mm

Width extended 485 mm

Dimensions when stored into transport bag:  
430 x 330 x h80 mm

Weight 2 kg

**Fixo Kid**

**ST00480C**

## QMX 777 ANATOMIC MATTRESS, BELT AND TELESCOPIC IV-POLE

QMX 777 is a mattress which presents many innovations, intended for stretchers used in transfer and rescue situations. Over the last few years new operative protocols have been affirmed regarding professionals and occasional operators.

Research has concentrated on new and more innovative plastic and expansive materials, designed to be used in extreme conditions and subjected to intensive use while always guaranteeing high standards.

We wanted a product that expresses stability, lightness, dynamism, resistance and security; reference values of an object of high technological content and elevated level of quality.

The structural parts are made with materials already experimented in other fields and the complete HFW technique gives the mattress characteristics of absolute impermeability.

The universal fixation system makes it possible to use with most stretchers.

### Technical Data

- Dimensions 1770 x 430 x h95 mm
- Weight 3 kg
- Waterproof

**QMX 777 black ST70000A**

**QMX 776 black ST70018A**

Medium density differentiated towards the centre to improve the containment of the patient and to adapt to all patient sizes

Generous HFW to improve impermeability



### TRACK 4-30

#### TELESCOPIC IV-POLE WITH FRAME FIXATION

Essential design and functionality. Easy to apply. The telescopic pole is made out of polished aluminium, while the frame fixation system is made of nylon. In order to fix IV-bottles or bags, the IV pole holder is equipped with a self-adherent strip, which is used also for frame fixation of the folded pole in the closed position.

**Track 4-30**

**IF01047C**



## STRETCHER ACCESSORIES

Technology develops at its best when it amplifies in a simple manner the pleasure of use. This embraces the Spencer philosophy and hence a series of accessories which improve

and optimize the stretcher's performance have been conceived. These innovations will transform your daily work.



### TANKER

#### POLYETHYLENE OXYGEN TANK HOLDER

This incredible tank carrier cannot be equalled for its compactness, lightness, protection and safety. It is made in high density polyethylene and is distinguished by the inserts and rings in rubber. The look of the Tanker, with its dedicated fixation system for the stretcher sidebar, reflects the way in which it protects the tank and the pressure reducer. The fastening mechanism allows for a rapid extraction and simple insertion. The innovative design favours the functionality and respects space thus reducing obstructions.

**Tanker for stretcher sidebar CB09025C**



### T-SIDE

#### TANKER CYLINDER HOLDER SUPPORT FOR SIDE BAR

T-SIDE is an accessory that completes the functionality of the Tanker oxygen cylinder holder allowing quick and safe fastening onto the stretcher.

Compatible with all Spencer stretchers equipped with Safe Bar.

Width 345 mm

Height 160 mm

Depth 95 mm

Weight 400 g

Material polyethylene

**T-side for Safebar CB09028C**



### OXYPACK

#### NYLON OXYGEN TANK CARRIER

Oxypack is made in tear proof, nylon Ripstop 600 D or easily washable SPEN-TEX. The compartment which contains the tank has an expansive, closed cell padding and a robust zipper closure, to ensure good protection should the tank itself receive any knocks. On the side of the tank holder a bag has been attached (also with a zipper closure) dedicated to the accessories for the administration of oxygen and a manual resuscitator.

**Oxypack 2 for stretcher**

**CB09012A**







# FOLDABLE STRETCHER

## 100 Series

The aluminium structure is characterised by its lightness and robustness. In order to guarantee stability on uneven surfaces, the feet are made of thermally treated aluminium.

The aluminium frame is connected to stainless steel spacers, to make the complete structure of the 100 Series completely rust proof.

Even on high loads, the stainless steel joints support the patient's weight longitudinally, avoiding problematic flexion.

The 600 D nylon sheet, covered with vinyl SPEN-TEX is impermeable, fire-resistant, high frequency welded, easy to wash and sanitise.

The entire 100 Series has been produced evaluating reduced clutter for storage space and transportation, offered by the structure that folds in half.

For this reason the emergency stretchers of the 100 Series are indispensable as reserve/subsidiary stretchers in the organisation of major emergencies, in industrial accident prevention and in sport.

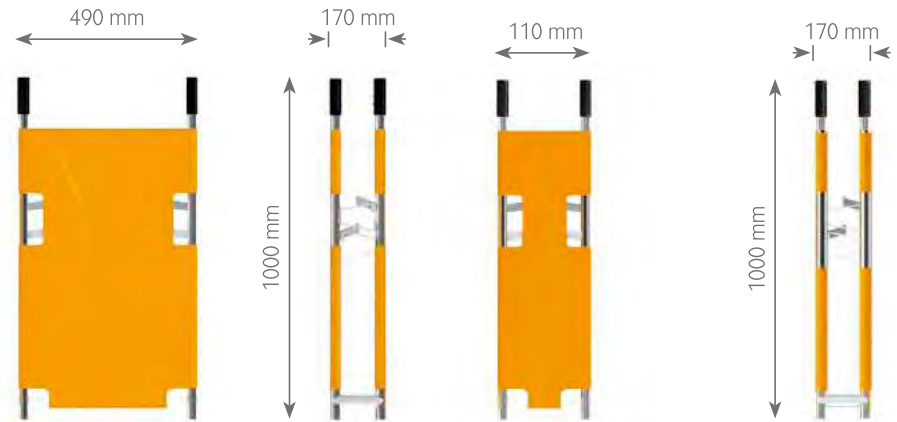

### SPENCER 100

#### LENGTHWISE FOLDABLE STRETCHER

Spencer 100 is used as a secondary stretcher in ambulances or as an emergency stretcher in industrial areas.

- Complete with two orange quick-release restraints
- Also available in decontamination version

**Spencer 100**

**ST30100A**

#### Technical data

Length 2010 mm  
 Length folded 1000 mm  
 Width 480 mm  
 Thickness folded 170 mm  
 Weight 5,5 kg  
 Materials Aluminum, steel, PVC  
 Load capacity 170 kg

### SPENCER 122

#### FOUR FOLD STRETCHER

Thanks to reduced clutter, the stretcher is used as an emergency stretcher and also in conditions where storage space lacks.

- Complete with two orange quick-release restraints
- Also available in decontamination version

**Spencer 122**

**ST00122A**

#### Technical data

Length 2010 mm  
 Length folded 1000 mm  
 Width 550 mm  
 Width closed 110 mm  
 Thickness folded 170 mm  
 Weight 6 kg  
 Materials Aluminum, steel, PVC  
 Load capacity 170 kg



## SPENCER SHELL

### UNIVERSAL BASKET STRETCHER

The Spencer basket stretcher Shell, has been studied to confront the most difficult of emergency situations. It is ideal for rescue operations in mines, at altitude and in water. Thanks to its robust form, resistance and flexibility of use, it is indispensable anytime that a reliable and safe stretcher is needed. A revolutionary technique has been used in its realization which ensures uniform thickness of the entire length of the stretcher. The shell is in high-density polyethylene and is joined to an aluminium framework that aims to consolidate its strength. The handles for transport, which are part of the structure itself, are placed along the entire perimeter. The grommets for the fixing of the spring catches of the harnessing are in stainless steel. Inside the shell there is a removable mattress, applied with self-adherent strips, made in closed-cell EPDM, which makes it impermeable to both blood and water. The use of high-density polyethylene for this shell guarantees not only that it is shatter-proof but also an exceptional sanitization. The Spencer Shell can hold a spine board.

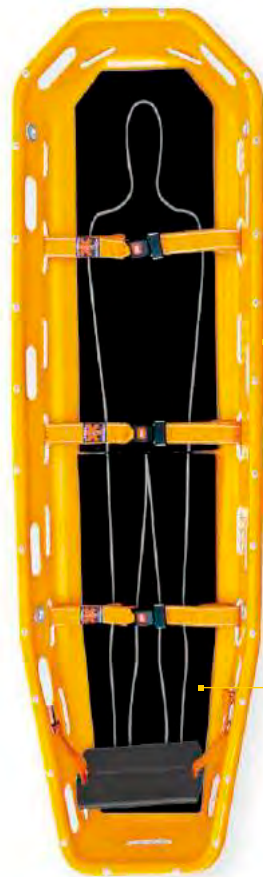

Runners on base to improve sliding on uneven surfaces

Mattress in expansive, closed cell polypropylene, water proof, easily sanitized, removable and replaceable

#### TECHNICAL DATA

- Nylon rope along entire perimeter
- Three 50 mm nylon belts with quick-release buckles
- Water resistant, closed-cell mattress
- Footrest in pre-formed polyethylene with position regulator
- Length 2140 mm
- Width 650 mm
- Height 190 mm
- Load capacity 280 kg
- Weight 12,5 kg

Spencer Shell orange

ST04000A

## TWIN SHELL

### DIVIDABLE BASKET STRETCHER

Twin Shell presents the same characteristics as the Shell stretcher with the only difference that it can be transversally divided in half to improve the storage and transport.

To ensure a perfect hold between the two shells, four nylon cones and a security system protected by a protuberance placed in the mould itself, have been inserted.

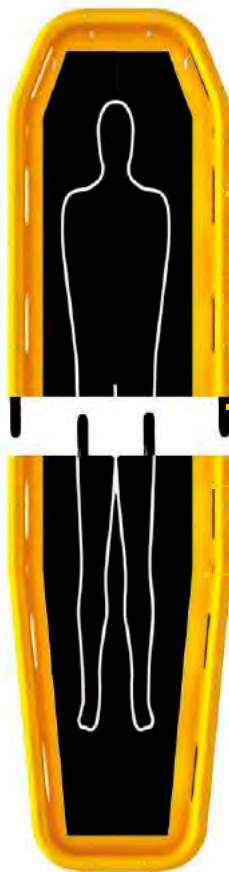

Easy and resistant safety  
bilateral system

Facilitated hold between  
the two shells thanks  
to the conical parts

Steel structure  
for the connecting parts

High-density polyethylene structure

#### TECHNICAL DATA

- Length 2140 mm
- Divided length 1180 mm
- Width 650 mm
- Height 190 mm
- Load capacity 280 kg
- Weight 14,8 kg

**Twin Shell yellow**  
**Twin Shell orange**

**ST04027A**  
**ST04020A**

## DAKAR

### BASKET STRETCHER WITH WHEELS

The Dakar introduces itself as the evolution of the original model while nevertheless being a true and real revolution. The projection of the style towards the future boasts a new image, which cleverly units rationality with functionality. To its dynamism we have added the style and technology necessary to face all kinds of operations, even the most intense and difficult ones. The new Dakar epitomizes the commitment of Spencer to the realization of a stretcher of exceptional structural qualities enclosed in a compact and secure shell.

A new stainless steel framework: a Spencer idea for uniting rationality and mobility in just one stretcher and to ensure to those who utilize it, both agility and security no matter what the terrain. The challenge is always the same; to develop a stretcher with dual personality.

A comfortable stretcher that maintains all the characteristics essential to the numerous methods of recovery. All of this, obviously, firmly anchored to Spencer technology.

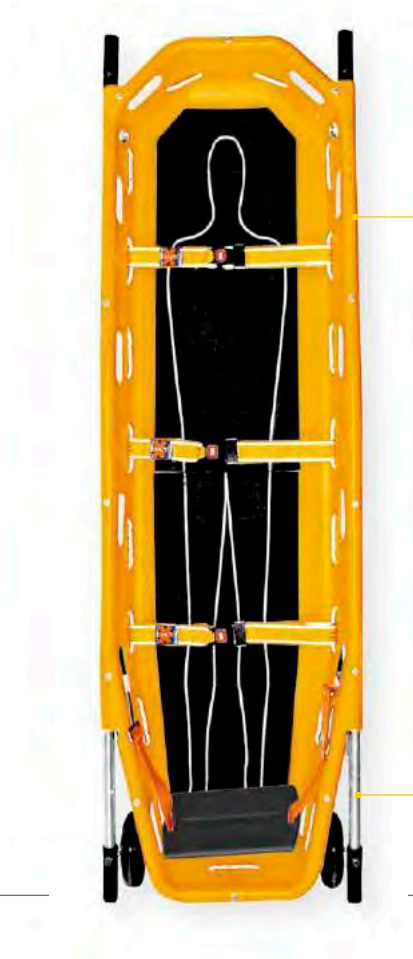

Twelve lateral handles  
with grip on the metal tube

Telescopic posterior  
handles, activated  
by the same handle

#### TECHNICAL DATA

- Length 2240 mm
- Width 640 mm
- Height 190 mm
- Load capacity 356 kg
- Weight 16 kg

Dakar orange

ST04070B

## SPENCER SX PICK UP STRETCHER

Thanks to the scoop action carried out by two longitudinal edges it is possible to position the stretcher below the patient without having to move him/her.

The scoop stretcher can be used to lift, transfer or transport the majority of patients.

Special attention has been given to the choice and definition of the material used in construction, which have to respond to certain needs: lightness, mechanical resistance, trustworthiness and durability.

The silhouette of the scoop stretcher has been studied to improve the insertion below the patient's body and at the same time stabilise when transferring or transporting.

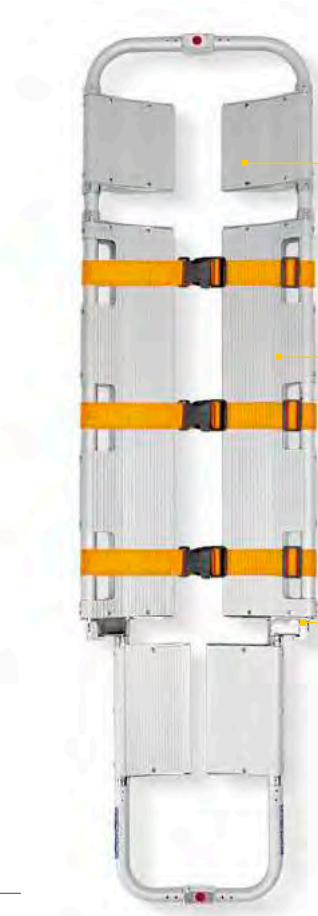

The extruding bars are fixed to the aluminium frame with the interposition of alloy fusions

The concave surface contains the patient and thanks to the extruded laminate profiles, lateral movements are minimised

Handle to select the length of the distal part of the stretcher

### TECHNICAL DATA

It is supplied with three fixation belts with quick release buckle.

- Minimum extension 1660 mm
- Maximum extension 2050 mm
- Folded extension 1200 mm
- Width 440 mm
- Thickness 70 mm
- Folded thickness 85 mm
- Weight Spencer SX 9,5 kg
- Weight Spencer SX Red Key 8 kg
- Load capacity 170 kg

**Spencer SX Red Key ST05001B**



## HP HIRVIN PLUS

### TRANSFER SHEET WITH INTEGRATED TRANSPORT BAG

Together with quality and reliability it also adds a new aspect.

In the HP version, the outside part has a compartment that allows you to store its case or a small cushion.

The case is made of non-tear nylon Ripstop, to store the HP rescue sheet neatly. During transport the case can be placed in the outside pocket of the sheet.



Lock cross stitching  
with electronic tension  
control

Double faced 50 mm nylon  
strap

Double stitching  
on the traversal straps

#### TECHNICAL DATA

- 550 D nylon double coated with poly-vinyl (SPEN-TEX)
- 50 mm nylon tape with breaking load under traction 600 kg
- Finishing to which enhances softness
- Cross lock stitching that exploits the new

- electronic control system of the tension of the thread (active tension), the length of the point and the width of the crosses
- Doubled in correspondence to all joining stitch subject to traction; all carried out with nylon thread

- The thread, as with the stitching system is very important because the stitching is made to last; a resistant, unbreakable nylon thread is used
- Dimensions 760 x 1850 mm

**HP Hirvin Plus orange**

**QM40500A**

# WOW

## CARRYING SHEET WITH 10 HANDLES AND FOOTREST

The carrying sheet WOW, is a device intended to transfer patients from the stretcher to the bed or for transport from

the rescue place to the stretcher for patients who do not have spinal injuries.

### WOW Unique features

- Manufactured with fireproof materials
- Easy to clean thanks to the use of non-absorbent fabrics
- Reinforced nylon webbing to ensure high resistance and durability
- The width of the tape used for the handles, ensures an easy grabbing increasing safety
- On the patient side there are handles dedicated to the patient that make him more collaborative and increase safety
- The special shape, offers high lateral containment during transport
- Footrest adjustable in 2 positions to increase longitudinal containment
- The supplied adjustable shoulder straps ensure a better distribution of the load on the rescuer
- The longitudinal aluminium rods, are removable through the dedicated holes and can be

folded into 3 parts. When inserted, they increase the rigidity of the sheet, allowing to distribute the load over a wider surface and allowing to limit the flexion of the device

- The device allows also the transport of the patient in sitting position
- Requires low storage space



\* The dummy is not included in the carrying sheet

### TECHNICAL DATA

- Storage dimensions 500 x 600 x 150 mm
- Dimensions of a folded rod 75 x 450 x 30 mm
- Length with extended footrest 2560 mm
- Length with folded footrest 1820 mm
- Upper part width 960 mm
- Lower part width 700 mm
- N° of handles 10
- Loading capacity 150 kg

- Materials Nylon, PVC, Al
- Weight with rods 4,7 kg
- N° of shoulder straps adjustments 6

WOW

QM40600B

## SHERPA

### FIELD STRETCHER CARRIER

Sherpa is the new solution for transporting stretchers and patients on any type of ground surface. It adapts perfectly to accommodate any type of field or emergency stretcher,

scoop stretcher or spinal board thanks to its characteristic construction. Thanks to the patented locking systems the wheels do not have to be removed so storage is easier and

space required is reduced. Sherpa makes it possible for a single operator to transport and it can also be used as a bed when in the parked position.



#### TECHNICAL DATA

- Frame 6082 aluminium alloy
- Stretcher support 6075 extruded aluminium alloy
- Patented stretcher block glass loaded nylon
- Frame and pantograph 6070 extruded aluminium alloy
- Locking levers 314 stainless steel
- Lubricant-free bushings teflon

- and polycarbonate
- Parking system Santoprene®
- Wheels extra large, anti puncture polyurethane wheels
- Surface treatment polished, anodised, epoxy paint

- Length open 995 mm
- Length closed 670 mm
- Width open 640 mm
- Width closed 300 mm
- Height 950 mm
- Weight 19 kg
- Load capacity 160 kg

**Sherpa ST00001C**

## TRANSPORT CHAIRS

The Spencer 407 chair is supplied with three polypropylene 50 mm straps.

### SPENCER 407

#### EVACUATION CHAIR WITH FOUR WHEELS

In addition to the amazing characteristics of the Spencer 406 model, extra structural elements have been added.

For example, two pirouetting wheels, complete with brakes for movement and on the axis and footrest to assist the correct posture of the patient. It is also possible to equip the chair with armrests and a large insertable posterior auxiliary handle.

#### Technical data

### SPENCER 407

Weight Spencer 407 12.5 kg

Spencer 407 ST00407A



### FIXATION

#### 10G WALL FIXING

10 g attachment system to be installed inside emergency vehicles, compatible with Spencer 407 models.

Dimensions on wall 645 x 305 x 150 mm

Materials Al, Nylon, Steel

Weight 1,65 kg

**10G Certified Wall Fixing**

Spencer 407

ST42705E



## TRANSPORT CHAIRS

The Spencer 402 chair is supplied with two polypropylene 50 mm straps.

### SPENCER 402

#### SPACE SAVING FOLDABLE CHAIR

We have called the Spencer 402 “the space saving chair”, a name that perfectly describes the philosophy that was behind the project. Confined dimensions and weighing only 9,5 kg, the frame guarantees a loading weight of 150 kg and offers incomparable movement. Its essential quality is the extremely fast opening and closing, thanks to innovative kinematics.

It is a versatile and dynamic device, which permits numerous uses and it has been designed especially for those who have to face space and organisation problems in sanitary or community vehicles.



### FIXATION

#### 10G WALL FIXING

10 g attachment system to be installed inside emergency vehicles, compatible with Spencer 402 transport chairs.

Dimensions on wall 650 x 320 x 120 mm

Materials Al, Nylon, Steel

Weight 1,65 kg

**Wall fixing for 402  
transport chair**

**ST42703E**

### Technical data

#### SPENCER 402

Weight Spencer 402/3 9.5 kg

**Spencer 402/3 with three wheels,**

**one of them autodirectional**

**ST00402B**



## SPENCER 4BELL AND FIXATION SYSTEM

The Spencer 4BELL chair is supplied with two polypropylene 50 mm straps.

### SPENCER 4BELL

THE REVOLUTIONARY SPENCER 4BELL 10 G EVACUATION CHAIR

Spencer 4BELL represents the evolution of the concept of evacuation. It offers maximum comfort and an ideal usability for both operators and the patient.

Rescuers will find absolutely innovative steps in this device that will effectively help you in evacuation and emergency procedures, minimizing effort and the margin of error.

### Technical data

#### SPENCER 4BELL

Length w/ handles closed

710 mm

Length w/ handles opened

1080 mm

Width 485

Height opened 905 mm

Rear wheels ø150 mm

Front wheels ø100 mm

Materials Aluminium, steel,  
PU, PVC

Loading capacity 180 kg

**Spencer 4BELL**

**ST10431B**



### 4BELL MAX

10G FASTENER FOR CHAIR 4BELL

Fastener intended for installation inside an ambulance, to be used with 4BELL chair. The device can be fixed both on wall or floor, according to the vehicle structure and equipment. The device is a standard equipment of the chair 4BELL.

Dimensions 505 x 450 x 220 mm

Materials PE, Nylon, Al

Weight 1,8 kg

**4BELL MAX**

**ST10432B**



## EMERGENCY EVACUATION CHAIR

The Eva chairs is supplied with two polypropylene 50 mm straps.

### EVA TRANSPORT CHAIR

#### FOR INTEGRATED MOBILITY

Eva is the stair chair designed for transfer of rescue patients, for transport and for evacuation and it presents a considerable number of completely new features.

Over the past few years new social concepts and new operational protocols have been adopted for both professionals and occasional operators. The aesthetic codes used by these new protagonists underline the new horizons of a more dynamic, brave and

anti conformist reality. Our designers have integrated these innovative concepts into the radically updated operational context with research being concentrated on the metals and the most innovative forms of plastics with the ability to operate under the most extreme conditions, able to guarantee absolutely the highest standards even with the most intensive use.

#### Technical data

##### EVA

Height Opened 1370mm

Height closed 950mm

Width 530mm

Frame Aluminium

Weight 19 kg

Load capacity 170 Kg

Front wheels 2 pivoting ø100mm

##### Eva E5

SK30009E



### E-MAX

#### 10 G OR 20 G FIXING SYSTEM FOR EVA STAIR CHAIR

E-Max is without doubt the best anchoring system available on the market today.

Just like Eva, E-Max also has a unique and innovative character.

Thanks to E-Max the stability of the chair on the ambulance is much better than any other normal fixing system. This guarantees not only improved safety features but also total silence of the device inside the ambulance during transport.

The handy anchoring system is pedal actuated and with a single movement the operator can block or unblock the device for use.

##### E-Max

Technical Data

Dimensions 320 x 155 x h425 mm

Weight 3.5 kg

E-Max 20 G SK30009E





# SKID SERIES EVACUATION CHAIRS

The simplicity of Spencer projects is the result of the intuitive nature of its interface.

In pursuit of the sublime balance where nothing is added nor removed, Spencer creates objects and instruments that can be used intuitively, "without thinking", in one of the most difficult sectors for designers: the production for use in not only evacuation scenarios, but also on a daily basis. An absolutely innovative project, part of the exclusive heritage of a unique worldwide manufacture.





## SKID SERIES

### EVACUATION CHAIRS

The Pro Skid-E chair is supplied with two polypropylene 50 mm straps.

#### PRO SKID-E

##### EVACUATION/TRANSPORT CHAIR

When looked at in more detail, the Pro Skid-E adopts the same frame and the same runners as the Skid-E, but above all with one difference regarding the use of a transport chair in respect to those of an evacuation chair.

In fact, a variation of the structure and of the weight distribution, associated with the application of convenient posterior handles make possible the use of Pro Skid-E also uphill.

Height opened 1580 mm

Height folded 1060 mm

Length with handles closed 1110 mm

Length with handles opened 1340 mm

Width 550 mm

Thickness folded 355 mm

Load capacity 150 kg

Materials Al, PVC, PE, PU

Front wheels  $\varnothing$ 100 mm, rear wheels  $\varnothing$ 200mm

Weight 15 kg

**Pro Skid-E silver**

**SK10201E**

**Pro Skid-E yellow**

**SK10001E**



Telescopic backrest to improve grip during descent

Retractable posterior handles

Adjustable strengthened seat

## SKID SERIES EVACUATION CHAIRS

The Skid-Ok chair is supplied with two polypropylene 50 mm straps.

### SKID-OK

#### LIGHTWEIGHT EVACUATION CHAIR

Skid-Ok reaches high quality standards through the use of innovative materials and components that make it lightweight and manoeuvrable, able to operate without compromise in any operational scenario.

It features an aluminium frame, welded and polished and an adjustable seat, reinforced with SPEN-TEX.

The innovative self braking system on the slides allows the operator a perfect control during the descent of the stairs.

Weight 11 kg

**Skid-Ok**

**SK20003E**

**Skid-Ok/B with armrests**

**SK20002E**



### DUST COVER

#### SKID-E AND PROSKID-E

The upper part of the cover is completed with elastic so that it adapts perfectly to the outline of the evacuation chair.

The front part has a transparent insert which permits location of the chair without having to remove the cover.

Developed for use with the wall mounting bracket (SK14000 wall fixing unit for Skid-E/ Proskid-E in closed position)

Compatible with all chairs series Skid, Skid-E and ProSkid and ProSkid-E with the exception of Skid Ready/Skid Ready-E/Skid-Ok.

**Dust cover Skid-E and Proskid-E**

**SK21002**



### WALL FIXATION

#### SYSTEM

Wall Bracket For Skid/Proskid

Dimensions 363 x 170 x 185 mm

**SK14000B**

### WALL FIXATION

#### SYSTEM

Wall Bracket For Skid-Ok

Dimensions 272 x 170 x 160 mm

**SK14001B**

## IMMOBILIZATION DEVICES

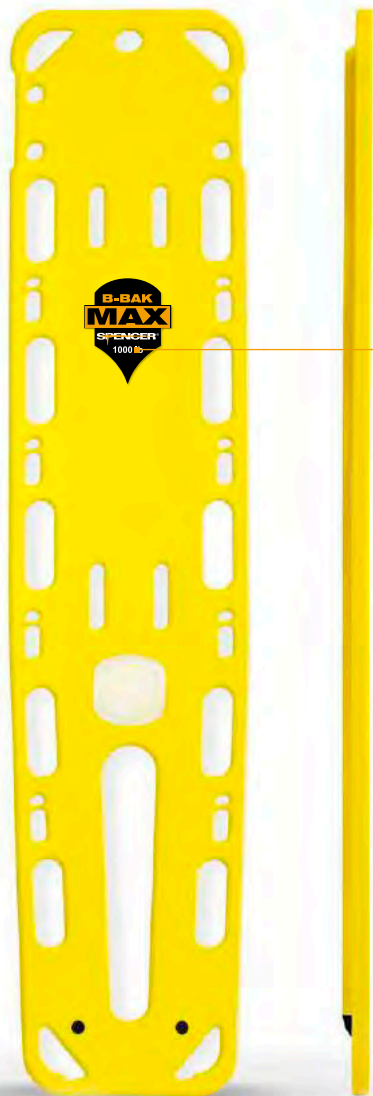

### B-BAK PIN / B-BAK PIN MAX

#### SPINE BOARD COMPLETE OF PINS

A special B-bak, very much appreciated by rescue teams, it puts together its famous technical characteristics and a built in system that allows to fix the restraints to the board.

The side handles are translucent incorporated elements, they allow you easy buckling-unbuckling operations for a fast and safe anchorage of the patient's restraints with shackle.



#### Technical data

Dimensions 405 x 45 x h1840 mm

Weight 6 kg

Load capacity B-bak Pin 180 kg

Load capacity B-bak Pin Max 454 kg

Functioning temperature from -10 to +50 °C

**B-bak Pin yellow** ST02061B

**B-bak Pin military** ST02069B

**B-bak Pin Max yellow** ST02067B

**B-bak Pin Max military** ST02068B

## IMMOBILIZATION DEVICES



### ROCK STRAPS

#### UNIVERSAL SPIDER STRAPS SYSTEM FOR SPINE BOARD

The Rock Straps system allows the complete immobilization of adult or paediatric patients onto Spencer spine boards but also onto other types of spine boards. Thanks to the diagonal parts, which move on the central belt, it adapts itself with precision to different body builds. Fixation is with self-adherent strips. To simplify use, the straps are colour-coded. They are made of strong but soft 50 mm nylon tape and are sewn together with special lockstitching techniques.

Weight 460 g

**Rock Straps**

**ST02035A**

### ROCK PIN

#### SPINE BOARD COMPLETE OF PINS

A special Rock, highly appreciated by rescue teams, puts together its famous technical characteristics and a built in system that allows to fix the restraints to the board.

The side handles are translucent incorporated elements, they make easy buckling-unbuckling operations for a fast and safe anchorage of the patient's restraints with carabiner.

The reduced thickness allows an easy storage of the spine board.

#### Technical data

Dimensions 445 x 50 x h1840 mm

Weight 7 kg

Load capacity 200 kg

Functioning temperature from -20 to +60 °C

**Rock Pin yellow** **ST02010B**

**Rock Pin orange** **ST02012B**

**Rock Pin red** **ST02013B**

**Rock Pin military** **ST02014B**

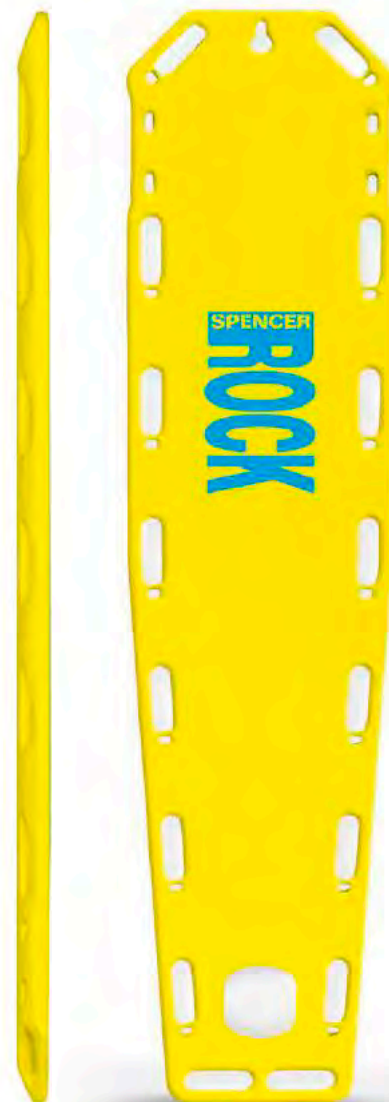



## IMMOBILIZATION DEVICES



### TANGO

#### INTEGRATED PAEDIATRIC AND ADULT SPINE BOARDS

In the world of emergency care, it is of great importance to optimize stocking space and to satisfy all requests for ergonomically advanced rescue equipment. Optimizing space and performance is the line Spencer drew on when introducing the new Tango.

A new design that brings together solidity, dynamics, space and performance and at the same time sets a new standard for high-performance spine boards. Great performance and above all, great for its attention towards the patient; adult and child.

An exclusive idea that allows two different profiles with one single product, reducing costs and stock volume. A paediatric and adult spine board always ready to collaborate together and each enhancing the other..

Weight 460 g

**Rock Straps**

**ST02035A**

### Technical data

Dimensions 445 x 55 x h1830 mm

Weight 8 kg

Load capacity 150 kg

Functioning temperature from -20 to +60 °C

**Tango ST02140**

### MARK UP

#### SYSTEM FOR PERMANENT PERSONALISATION

Two shells set one against each other, unit and close together thanks to a large gasket and an ingenious, watertight, irreversible clamp, which contains a personalised plaque. A completely new, unedited and patented system manufactured in transparent polycarbonate which permits a permanent, un-removable personalization of the spinal board.

**Mark UP**

**ST02106A**

## IMMOBILIZATION DEVICES

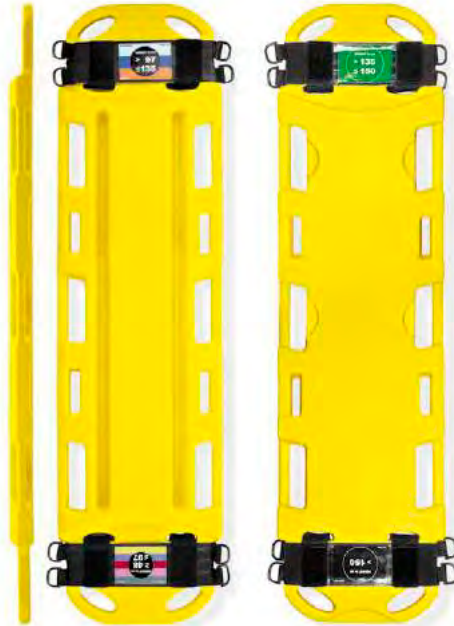

### BABY GO

#### MODULAR PAEDIATRIC SPINE BOARD

Caring for children is a completely different world of rescue and children should not be considered “small adults”. Baby Go is a professional support which optimises the positioning and maintains the spine in neutral position with the ideal alignment for air flow. This is the reason we have moulded the spinal board with four different profiles which guarantee the correct alignment of the child according to his body size.

#### Technical data

Dimensions 320 x 45 x h1200 mm

Weight 3 kg

Load capacity 30 kg

Functioning temperature from -20 to +60 °C

**Baby Go**

**ST02141B**



### RSP

#### PAEDIATRIC SPIDER STRAPS SYSTEM FOR SPINE BOARD

The centre tape can be used as a tape measure to measure the height of paediatric patients.

Central belt length 750 mm

Minimum length “V” belts 420 mm

Maximum length “V” belts 610 mm

Minimum width 520 mm

Maximum width 610 mm

Integrated measuring tape range 1500 mm

Material Nylon

Weight 460 g

**RSP**

**ST02018A**

## SPENCER HEAD IMMOBILIZERS

The continuous evolution of immobilization technology and technical construction solutions have imposed on medical device manufacturers the use of innovative and high performance materials.

Spencer, who invests substantially on research, can efficiently demonstrate this evolutionary process.

We are very proud to present this range of head immobilizers that will allow you also to

satisfy your immobilization requirements during transport and at the same time have the Spencer product quality and life span.



### SPENCER CONTOUR

#### ANATOMIC UNIVERSAL HEAD IMMOBILIZER

The exclusive form of the head immobilizer has been designed by rescue experts and has been tested on the road. This form physiologically supports the brain case, avoiding as much as possible further compression of the cranium and completing the immobilization of the rachis supplied by the cervical collar.

Spencer Contour head immobilizer is composed of two mono blocks, made of a soft plastic material and a base with belts to fix to various kinds of stretchers. Holes have been made inside the two shells, which allow the inspection of the aural pavilions, permitting the verification of any loss of blood or liquids.

Weight Spencer Contour 1.5 kg

**Spencer Contour yellow**

**SH00201A**



### SUPER

#### COMPACT UNIVERSAL HEAD IMMOBILIZER

Indispensable for head immobilization.

The Super can be used with spine boards and the scoop stretcher. It is made of high density foam, covered with water repellent material.

- Easy to use
- Washable and easy to stock
- The head supports have an anatomic profile and offer a stable and comfortable support
- The head support's positions can be adjusted thanks to the use of a highly resistant type of self-adherent strips
- The head immobilizing straps are made out of polypropylene and are padded in the part in contact with the patient's face

Weight Super 1.5 kg

**Super Blue**

**SH00110C**





# EXTRICATION DEVICE

## SED

### EXTRICATION/SPINE IMMOBILIZATION DEVICE

Spencer Extrication Device is an instrument for extrication and spine immobilization, ideal for all emergency situations.



Particularly suitable for victims blocked in vehicles, collapsed buildings and disaster scenes. It can also be used with pregnant women, children and babies. It is ideal for the immobilization of the hip and pelvis fractures. The covering made of robust nylon covered in vinyl limits abrasions and assures total integrity. The vertical rigidity and the horizontal flexibility are the main characteristics of this device, which allows a rapid immobilization of the spinal column and a secure extrication. The belts and the buckles are coloured for easy recognition.

### Specific Characteristics

#### SED

- » Color coded belt system to make the application more intuitive and rapid
- » PVC coating for an easy sanitation
- » The separation of the rigid elements, allows high vertical rigidity and horizontal flexibility.
- » Equipped with cushion for the nuchal area

### Technical data

Dimensions folded  
with bag 850x250x120 mm  
Length 830 mm  
Width 900 mm  
Maximum thickness 25 mm  
Belts length 74 cm  
Materials PVC, Nylon  
Weight without bag 2,60 kg  
Weight with bag 2,85 kg  
Loading capacity 230 kg

SED

SR00111B



## CDK

### TAPERED VACUUM MATTRESS AND ACCESSORIES



#### CDK

##### TAPERED VACUUM MATTRESS

CDK is a classic vacuum mattress, it is robust and reliable. The lower part of the CDK is fitted with a rope reinforced with Santoprene® handgrips to ensure an easy handling system.

On the top part the combination of the cord and the handles serves as a strong loop to attach the patient fixation belts. The top side is orange and the bottom side is grey.

The on/off valve made of chromed brass with a built-in fitting for rubber tube is resistant to any temperature and guarantees unlimited duration.

##### Technical data

Dimension 2150 x 900 mm

N° of handles 9

Weight 4.1 kg

Materials Al, PP, PVC, Nylon

Functioning temperature from -30 to +70 °C

CDK orange

QM22300A

#### QMX 170

##### BAG FOR VACUUM MATTRESS

SPEN-TEX carrying bag for the mattress. The zip bag helps protect the mattress from atmospheric agents and makes it easily accessible for use. Not suitable for Combimatt.

Dimensions 750 x 710 mm

QMX 170

QM22170A



#### QMX 120

##### ALUMINIUM VACUUM PUMP FOR VACUUM SYSTEMS

Aluminium body, zinc laminated anti-slip pedal, plunger mechanically fixed to the knob. Characteristics that permit the necessary strength to generate void in vacuum mattresses. The connecting tube with a wide gauge, attached to a unique one-way valve, guarantees good flow and speeds up rescue operations.

Height 501 mm

Weight QMX 120 1.3 kg

Air chamber gauge 57 mm

length camera 285 mm

tube length 1000 mm

QMX 120

QM22120A



# INFLATABLE SPLINTS

## URRÀ KIT

### IMMOBILIZATION KIT

Tall you need for the treatment of fractures and sprains in a small container with com partments.

It contains

- Three Urr Splints in different sizes
- One Spencer Ice Pack instant ice
- Universal bandage scissors
- White self-adhesive flexible bandage (10 x 630 mm)
- Bag made of strong material, complete with compartments to contain all that

is necessary

Dimensions: 260 x 85 x h240 mm

Weight 718 g

**Urrá Kit JM90003A**



## ECO AIR SPLINT

### INFLATABLE SPLINTS

The Eco Air Splint kit contains

- Three splints of different sizes for the arm
- Three splints of different sizes for the leg
- bag made of unbreakable nylon for the containment of the splints

Dimensions 330 x 50 x h420 mm

Weight 1,5 kg

Functioning temperature from -10 to +60 °C

Storage temperature from -20 to +60 °C

**Eco Air Splint Kit QS24200A**



# SPLINTS

## BLUE SPLINT

### RIGID SPLINTS WITH FLEXIBLE INTERNAL STRUCTURE

A handy system created by Spencer to immobilize joints effectively and simply. The Blue Splint immobilization system, made in five shapes, has changed its way of treating fractured or sprained joints.

All splints can be modelled according to the necessity of each case and once obtained the desired profile, the splint will offer extraordinary rigidity.

To align the splint in a straight position it is sufficient to straighten by hand the inside structure.

Blue Splints are extremely light and could be overlapped with each other to create an infinity of configurations and solutions.

They can be used for adults and children of any size.

Perfect for

- Ambulances
- Medical cars
- Mountain rescue
- Sport medicine
- Water rescue
- Orthopaedic centres
- First aid and any kinds of emergency departments.

Functioning temperature from  $-40$  to  $+60$  °C

Storage temperature from  $-40$  to  $+86$  °C

**Blue Splint Kit**

**JM80002A**



Used to immobilize wrist fractures  
(302 x 255 mm)



Used for adult forearm or child leg  
immobilization (387 x 300 mm)



Used for ankle, elbow  
immobilization or as an armrest  
during vein infusions  
(540 x 305 mm)



Used for immobilization of adult  
upper limbs or child lower limbs  
(582 x 290 mm)



Used to immobilize the adult  
lower limbs (578 x 420 mm)





## SYSTEM

### TRACTION/IMMOBILIZATION SYSTEM

#### DAVIS SERIES

##### TRACTION/IMMOBILIZATION SYSTEM

Davis is a traction/immobilization system, studied to immobilize fractures of the femur and consequently to ease pain, prevent damage to the tendons, vascular and muscular tissues. Davis is easy to apply thanks to belts with self-adherent strips closures and soft band for the lifting of the ankles.

Its exclusive traction mechanism re aligns the fractured femur into the correct position.

It restores the pressure of the tissues back to the traumatised leg, limiting haemorrhagic losses; it avoids damage to the nervous, vascular, muscular and bone tissues.

Davis is supplied with

- Serrated traction mechanism and “S” sha-ped coupler
- Supporting feet and ring for the release of the blocking coupler
- Four padded support straps for the leg
- Strap and ischial padding
- Extendable strap for the ankle
- Transport bag

#### Technical data

##### DAVIS ADULT

Minimum length 890 mm  
Maximum length 1350 mm  
Width 210 mm  
Base width 230 mm  
Weight 1,78 kg  
Materials Steel, Al, Nylon

Davis adult

SR01010A



#### Technical data

##### DAVIS PAEDIATRIC

Minimum length 810 mm  
Maximum length 1170 mm  
Width 185 mm  
Base width 225 mm  
Weight 1,58 kg  
Materials Steel, Al, Nylon

Davis paediatric

SR02020A

# ANTI-SHOCK TROUSERS

## JACOB

### ANTI-SHOCK TROUSERS

Jacob is designed to allow rescue operators a rapid and simple application on patients that have hypovolumetric shock.

- Adjustable in different sizes
- Separate replaceable air chambers
- Made to be long lasting: the three air chambers are separate and made of polyurethane welded with a HFW process
- The pressure of every chamber is monitored independently
- The pressure of the homogeneity around the legs is guaranteed by the design of the chambers, which adapts to patients of different sizes
- Rapid fastening made of self-adherent strips with different colours to allow quick fixation
- The large inguinal opening allows access to the femoral vessels for the catheterisation or collection of blood, without having to reduce the pressure
- The transport bag, made of tear proof material can carry the Jacob anti-shock trousers and the inflation pump; the container is over dimensioned to allow the contemporary transportation of other emergency instruments
- The exceptionally trustworthy automatic outlet valves assure long life. Manufactured in aluminium they are preset for the emission of air between 135 and 145 mm Hg when the anti-shock trousers are used without a gauge; the over pressure valves ensure automatic emission of excess air
- Available in adult and paediatric sizes
- Navy blue with yellow prin



### Technical data

#### JACOB

Dimensions adult 1190 x 520 mm

Dimensions paediatric 785 x 380 mm

Materials Nylon, TPU, PU

Weight adult 4,2 kg

Weight paediatric 3,5 kg

**Jacob adult**

**AK01000A**

**Jacob paediatric**

**AK01011A**

## ELECTRONIC PULMONARY VENTILATOR



### SPENCER 170

#### ELECTRONIC PULMONARY VENTILATOR

Spencer 170 is electronically controlled and works as a time-cycled pressure limited pneumatic unit with intermittent flow.

The wide range of volumes and respiratory frequencies allows use with adults or with children.

An exclusive system allows a stable mix of oxygen with air, despite the ventilation/minute, the frequency and the insufflations pressure

The compact structure, lightness, alarms, the simplicity of regulation allow secure use even by lay people.

The non-rebreathing valve is supplied with a special pressure limiting device that can be used for adults or children.

Thousands of ventilators used all over the world make a trustworthy point of reference in the mechanical ventilation scenario.

The control instruments are designed in such a way as to allow clear and immediate reading. The indications have been reduced to the essentials and the commands are positioned logically to be just in the right place.

Complete with

- PVC patient circuit tube
- Spencer Mask size 4
- Non-rebreathing valve

#### Technical data

Drive electronic control  
Ventilation mode controlled  
Frequency from 5 to 30 BpM  
Volume/minute from 2 to 20 L/min  
I/E connection 1/2  
Oxygen concentration from 60 to 100%  
Security valve 60 mbar  
Inlet pressure 3,5 bar  $\pm$ 0,5  
Battery duration around 2 hours  
Patient circuit corrugated tube  
Non-breathing valve autoclavable  
Medical gas alarm sounding

Battery alarm visual/sounding  
Vacuum manometer from -20 to +70 mbar  
External power supply 12 Vdc  
Internal battery Pb 12 Vdc  
Structure varnished aluminium  
with epoxy powder  
Panel permanent polycarbonate  
Dimensions 295 x 160 x h155 mm  
Weight 3 kg

**Spencer 170**

**EV01170**

# ELECTRONIC PULMONARY VENTILATOR



## SPENCER 190

### ELECTRONIC PULMONARY VENTILATOR

Spencer 190 is a pulmonary ventilator of the latest generation, with a one stroke cycle, limited to pressure and controlled by a powerful micro-processor. It guarantees flowing pressure, respiratory frequency and constant fraction of inspired oxygen, independent from the insufflation pressure.

There are three modes of ventilation: controlled, assisted and assisted/controlled (ABS). The respiratory act is completely monitored. When ABS is inserted the form of the luminous wave allows easy synchronisation of the instrument with the patient. The safety of the patient is guaranteed by monitoring systems and alarms of the airway pressure, power pressure and apnea. The compact structure, limited weight, simplicity of regulation and control of the parameters, the incorporated visual and acoustic security devices allow safe use even by untrained lay people.

The control instruments are designed in such a way as to allow clear and immediate reading. The indications have been reduced to the essentials and the commands are logically positioned.

Complete with

- PVC patient circuit tube
- Spencer Mask size 4
- non-rebreathing valve

The Kompak and Porta Vent version are available.

Dimensions 330 x 175 x h180 mm

Weight 4,8 kg

## Technical data

Drive: microprocessor

Ventilation mode controlled - assisted  
- assisted/controlled (ABS)

Frequency from 5 to 40 BpM

Volume/minute from 2 to 20 L/min

I/E connection 1/2

Sensitivity trigger from -2 to -12 mbar

Oxygen concentration from 60 to 100%

Security valve 60 mbar

Overpressure alarm

- adults 55 mbar
- children 25 mbar

Inlet pressure 3,5 bar  $\pm$ 0,5

Battery duration around 2 hours

Patient circuit corrugated tube

Non-breathing valve autoclavable

Alarms maximum pressure, minimum pressure, apnea, battery, software failure

Luminous indications spontaneous inhalation and ventilation mode

Reset alarms 30 sec

LED test

Digital keys

Vacuum manometer from -20 to +70 mbar

External power supply 12 Vdc

Internal battery Pb 12 Vdc

Structure varnished aluminium with epoxy powder

Panel permanent polycarbonate

**Spencer 190**

**EV01190A**



## ELECTRONIC PULMONARY VENTILATOR



### SPENCER 118

#### PNEUMATIC LUNG VENTILATOR

A protagonist with a great past made up of more than ten years of managing and measuring the parameters of mechanic ventilation. Spencer faces the future determined to remain one of the most qualified and in some ways the most original manufacturer in the world of respiratory emergency ventilators for transport.

Each mechanical or electronic respirator with the famous star brand, be it a classic or a new entry, can be considered an instrument of great reliability and sophisticated technology, just as you expect from a product which creates a synthesis between vocation and more than ten-years of experience.

Versatile, simple and economical, Spencer 118 is a ventilator totally pneumatic.

It guarantees time-cycled controlled ventilation with pressure limitation and constant square shape flow waves.

The control instruments are positioned to allow clear and immediate reading in exactly the position you would expect them to be. Its intrinsic properties, the integrated electronic alarm systems and its reduced dimensions make it particularly suitable for use outside of the hospital.

#### Technical data

Drive Fluidic logic

Ventilation mode VC-CMV (CMV)

Frequency from 10 to 70 BpM

Flow from 2 to 20 L/min

I/E ratio 1:2.0  $\pm$ 0,3 at 10bpm 1:1.5  $\pm$ 0,3 at 70bpm

linearly adjustable between the two values

Oxygen concentration 60% (AIR MIX) or 100% (NO AIR MIX)

Medical gas supply: from 280 to 600 kPa

Alarms High pressure (acoustic) , Pneumatic supply (visual)

Manovacuumeter from -20 to +80 cm H<sub>2</sub>O

Materials Aluminium, PE

Supplied with

- patient circuit tube
- face mask
- patient valve

Dimensions 270 x 177 x h210 mm

Weight 3,8 kg

**Spencer 118**

**EV21118B**

## RESUSCITATOR AND FACE MASKS



B-life adult BG03027A



B-life paediatric BG03033A



B-life neonatal BG03051A

### B-LIFE

#### SILICON RESUSCITATOR

The new B-life resuscitators are made from very resistant materials, silicon and polysulphonate, that guarantee exceptional durability. The new form of the self-expanding resuscitator guarantees great flexibility, re-expansion of the resuscitator, versatility, ease of use and reliability. The dead space of the valve is only 7 ml [0,24 fl oz]. All of the parts are completely autoclavable. The diameter of the connection ISO 15/22 mm. All of the models are supplied with

- Transparent patient valve with swivelling connector, self-locking connection to avoid accidental disconnections, characterised by a small dead space
- Disposable reservoir bag for the administration of oxygen
- Face mask
- PEEP valve

#### On request they can be supplied with

- Easily removed pressure limiting valve
- Transparent oxygen reservoir valve, which supplies a higher oxygen concentration (up to 97%) and minor oxygen consumption

#### Available in the following versions

- Adult: for patients over 30 kg
- Paediatric for patients between 7 and 30 kg
- neonatal for patients under 7 kg

### B-LIFE

#### SILICONE FACE MASKS

B-life face masks are ideal for use in anaesthesia and in assisted and controlled ventilation. They are autoclavable and characterised by maximum adhesion. The connecting ring is soft to guarantee easy attachment and to avoid disconnection.

The shape of the transparent shell makes them comfortable for the operator and also on the patient's face.

It is supplied with a standard ISO connection 15/22 mm and minimal dead space.

**B-life Kit six sizes**

**RM20410B**



# RESUSCITATION SYSTEM AND FACE PROTECTION

## STAR MASK

### FACE PROTECTION FOR CPR

An essential protective barrier, it allows a trained rescuer to have a determined approach to CPR. A must to keep with your key ring or wallet.

#### Characteristics product

- Folding, you can even keep in the portfolio
- The hydrophobic filter reduces the risk of contact with saliva or blood of the patient
- Printed instructions on PVC

Star Mask

TA01002B



## FLEX MASK

### FLEX MASK WITH EVA BOX

Soft and elegant container in EVA equipped with loop with automatic closure for belts. Flex Mask can be used any time that it is necessary to reanimate a cardiac arrest patient. The air flow can be enriched with oxygen by removal of the cap and insertion of the oxygen tube. The soft air filled cushion guarantees perfect adhesion of the mask to the patient's face.

Flex Mask with EVA box

TA09050A



# LARYNGOSCOPE HOLDERS

## LSK SERIES

To work well is also to work with style. This is why Spencer offers a range of laryngoscope holders created by the unmistakable hand of our designer. Not only are they attractive to look at but above all perfectly efficient and rich with intelligent working solutions. Ideal for professional use, exceptional for their compactness and the protection they

offer, they will also give your work an image of quality.

All kits in the LSK Series which contain a conventional light or fibre-optic adult handle are integrated with the innovative and exclusive silicone Grip Up handle holder which guarantees the user an extremely pleasant, firm ergonomic grip.

## LSK 1

### LARYNGOSCOPE KIT TEN BLADES

A container that can boast the qualities of lightness, mobility, functionality, resistance and durability. Due to its design and versatility, it can easily be inserted in all the backpacks, bags and cases, answering the call for different uses. It is made in expansive polyethylene and Lycra, is compact and shockproof and has a zip closure. Inside there are areas for the placing of blades and handles for laryngoscopes which are well protected thanks to the use of elastic loops. In order to ensure a correct positioning, there is also a padded flap between the two shells.

#### LSK 1 contains

- A conventional light adult handle
- A conventional light paediatric handle
- five Macintosh blades
- five Miller blades

Also available in fibre-optic version.

Dimensions 230 x 75 x h230 mm

Weight empty 500 g

Weight complete 1,5 kg

**LSK 1 kit conventional light DG03113B**

## FLEX MASK

### WITH MATERIAL BOX

Flex Mask can be stored in a case made of unbreakable nylon with a belt loop.

**Flex Mask with material box**

**TA09039A**





## BOARD AND RESUSCITATION CASE

### KDX 1

#### RESUSCITATION CASE

These cases are destined for special uses because they are developed to resist to shocks, water, corrosives, dust and environmental circumstances. Made out of a heat-shaped polyethylene co-polymer which makes them extremely resistant to shocks. One of the most important characteristics is the complete resistance to water (they even float), guaranteed by the neoprene packing, the manual pressure valve, high resistance to chemicals and the possibility to adopt special safety locks. Internally they can be equipped with a special pre-formed polyethylene foam, with a one square centimetre cube-matrix, which can be formed around the objects it contains.

The cases are all equipped with metal internal supports, for the placement of small panels or boxes for fixing the content.

**KDX 1 empty**

**CB06045C**



### RES-Q-BOARD

#### RESUSCITATION BOARD

Res-Q-Board has been designed to optimise CPR manoeuvres. The anatomic form allows the correct positioning of the patient, maintaining the airways open and at the same time making external cardiac massage more effective.

The superior surface is structured to reduce slipping and to support the vertebrae. The inferior surface is made to stabilise the board during resuscitation. The handles make it extremely manageable and transportable, making operations such as anchorage and the transfer of patients much easier.

Res-Q-Board is light and resistant to compression, because it is made of high density polyethylene, double shell without seams. It is easy to use and it is really handy for training CPR with first aid responders. It is indispensable on ambulance stretchers during the transportation of critical patients and in all hospital wards, in order to be able to carry out CPR. The monolithic structure allows quick sanitisation.

Dimensions 415 x 70 x h605 mm

**Res-Q-Board orange**

**RB70000A**





# MANUAL ASPIRATOR

## B-VAC

### MANUAL ASPIRATOR FOR SECRETIONS

B-Vac is an aspirator for secretions which is easy to use, portable, stable and compact and which generates a vacuum of -550 mmHg. Just one hand is sufficient to generate the vacuum. An essential design allows for ambidextrous use. In order to guarantee efficiency and precision the B-Vac incorporates a novel and practical system which permits selection for use on either adult or paediatric patients. In order to guarantee viral and bacterial protection the product has an easily replaceable filter. The use of the latest generation of techno polymers for the construction ensures a long life and easy sanitation.

#### B-Vac with adult tube

##### Technical data

Dimensions with vessel 210 x 170 x 75 mm

Adult catheter dimensions  $\varnothing 16 \times 22$  cm

Max Vacuum 550 mmHg

Flow  $>20$  l/min

Vessel's capacity 350 ml

Viral and bacterial filtration efficiency 99,99%

Materials PE, PVC

Aspirator's weight w/vessel 270 g

Weight adult catheter 30 g

Vacuum selector 100% or 50%

RV71150B



## RES-Q-VAC

### MANUAL SUCTION PUMP

Res-Q-Vac is an easy to use suction pump, portable, stable and compact, capable of generating a suction of -300 mm Hg [-11.81 in Hg] by pressing the pedal with hand, knee or foot.

In emergency situations it allows clearing of patients' airways safely, quickly and efficiently.

The precision of the wiring and the solid structure assure a long lasting product.

The structure made of polycarbonate is strong and is very easy to clean. The autoclavable vase is complete with an overspill valve.

If you think of a suction pump independent of any power source, compact and light but at the same time strong and efficient, with a competitive price then Res-Q-Vac is the one for you.

Res-Q-Vac yellow

RV71130B





## COMPACT SUCTION DEVICE

Innovation is the keyword for all Spencer's projects related to suction.

Every product is born from a synthesis of technology, aesthetics and functionality regardless of it being a new range, increased versatility in use or for a particular application.

In this way Spencer has created devices with a great personality, which have been adopted in the world of emergency, both for completing ambulance equipment packages and on the field.



### PORTA VAC

#### COMPACT SUCTION DEVICE

The impressive simplicity of the shapes of this model, together with the distinguished technical characteristics which guarantee extreme functionality, immediately attract attention. The rectangular vacuum chamber perfectly integrates with the shapes of the body and is placed in a protected position, perfectly visible from above.

The high-capacity engine does not need any maintenance and easily creates high grades of vacuum (-600 mm Hg).

The Porta Vac is equipped with a local power source plug, allowing quick recharging of the batteries and/or functioning with net-energy.

Porta Vac can be supplied with a comfortable carrying bag, which can contain all the accessories, and with the metal wall-support for fixation on emergency vehicles.

#### Technical data

Dimensions 370 x 100 x 240 mm

Weight 5,5 kg

Vacuum Range 0-600 mmHg

Flow (free flow) 18 L/min

Noise level 60 db

Electrical connection requirements  
(battery charger) 100-240V~50-60Hz

Battery 12VDC 3Ah Pb

Vase capacity 1000 ml

**Porta Vac**

**SC60001A**



## PORTABLE COMPACT SUCTION UNIT



### Technical data SC75560

Jet Dimensions 200 x 225 x 285 mm  
Jet Dimensions w / fixing 200 x 250 x 320 mm  
Suction device weight 2,65 kg  
Fixing weight 0,8 kg  
Vacuum Range From 50 to 550 mmHg  
Flow (free flow) 32 l/min  
Noise level 70 db  
Electrical connection requirements  
100-240 VAC 47-63 Hz 0,75A max; 12VDC  
33W max

IP Grade IP12  
Battery 12V DC Ni-MH  
Battery operating time 5 h  
Container capacity 1000 ml  
Patient tube length 1,8 m  
Operating temp. From 0°C to +45°C  
Storage temp. From - 40°C to +70°C  
Umidity From 0 to 95%

### AMBUJET

#### PORTABLE SUCTION UNIT FOR AMBULANCE

Durable, lightweight, stable, compact, practical. In just one word AmbuJet. The new Spencer suction unit.

The most advanced in the world. The only suction unit with an integral indestructible polyethylene shell able to fully protect both the unit and the vase from bumps and impact damage.

The world's lightest vacuum device at just 2,65 kg but also the most compact and stable thanks to its extraordinary geometric architecture.

AMBUJET is the one and only suction device equipped with a certified 20 G fixing system made super easy to use thanks to the speed at which the battery can be substituted and no hassle direct connection of the vase to the suction unit which makes installation of the container fast and simple and reduces the number of components and repair costs.

<b>AMBUJET P 1000 R 10 G</b>	<b>SC75650C</b>
<b>AMBUJET P 1000 B 10G</b>	<b>SC75560D</b>
<b>AMBUJET P 800D 10G</b>	<b>SC75550C</b>

# PORTABLE SUCTION UNIT

## TECHNICAL SHEET



### JET COMPACT

#### GENERAL CHARACTERISTICS

Weight 1.6 kg  
 Dimensions 220 x 70 x h180 mm  
 Vacuum Range mmHg from 50 to 550 mmHg  
 Suction rate 32 Lpm  
 Acoustics Level 70 dB  
 Latex free

#### BUMPERS

No bumper

#### ELECTRONIC

Electrical requirements 100-240 VAC 47-63 Hz 0.75 A max I 12 VDC, 33 W max  
 Type of battery 12V DC Ni-MH  
 Battery functioning 30 min on, 30 min off  
 Battery charging time 5 hours  
 12V Power connection included  
 220V Power source not included

#### COLLECTION VASE

300 ml Single use vase



### HOME JET

#### GENERAL CHARACTERISTICS

Weight 2.65 kg  
 Dimensions 200 x 225 x h285 mm  
 Vacuum Range mmHg from 50 to 550 mmHg  
 Suction rate 32 Lpm  
 Acoustics Level 70 dB  
 Latex free  
 Shoulder strap included

#### BUMPERS

Integral protection shell in polyethylene

#### ELECTRONIC

Electrical requirements 100-240 VAC 47-63 Hz 0.75 A max I 12 VDC, 33 W max  
 Type of battery 12V DC Ni-MH  
 Battery functioning 30 min on, 30 min off  
 Battery charging time 5 hours  
 12V Power connection included  
 220V Power source not included

#### COLLECTION VASE

800 ml Single use vase  
 1000 ml Reusable vase  
 1000 ml Serres single use liner



### AMBUJET

#### GENERAL CHARACTERISTICS

Weight 2.65 kg (+ 0.8 kg hook)  
 Dimensions 200 x 225 x h285  
 Dimensions with fixing: 200 x 250 x h320 mm  
 Vacuum Range mmHg from 50 to 550 mmHg  
 Suction rate 32 Lpm  
 Acoustics Level 70 dB  
 Latex free  
 Shoulder strap included

#### BUMPERS

Integral protection shell in polyethylene

#### ELECTRONIC

Electrical requirements 100-240 VAC 47-63 Hz 0.75 A max I 12 VDC, 33 W max  
 Type of battery 12V DC Ni-MH  
 Battery functioning 30 min on, 30 min off  
 Battery charging time 5 hours 12V Power connection included (only for codes SC75700C, SC75710D, SC75750C, SC75760D, SC75800C, SC75850C)  
 220V Power source: not included

#### COLLECTION VASE

800 ml Single use vase  
 1000 ml Reusable vase  
 1000 ml Serres single use liner

# ANEROID SPHYGMOMANOMETER



## VISO BUMPER

### ANEROID SPHYGMOMANOMETER WITH LARGE DIAL AND PROTECTION

Viso Bumper is a high quality sphygmomanometer which distinguishes itself for its interesting quality/price ratio. It is particularly large and stable and with no problem it will impose easily in daily rescue and transport activities.

The ABS wall support is extraordinarily strong and thanks to a simple mechanism, it allows a wide rotation. But Viso Bumper goes further because it has been projected to equip ambulances; the outer shell is an assuring element made of unbreakable material based on shockproof thermoplastic rubber resistant both to bumps and bangs and to chemical products. We have also reserved a space on the outside to personalize this instrument in a permanent way.

Single packaging in cardboard box printed using a four-coloured process.

Spencer also offers a wide range of cuffs in different sizes.

The 10 G version is available.

A spacey basket made of strong ABS for cuff and tube in the back of the instrument.  
Easy to clean.



Thanks to a special space within the mould shell, you can personalize the Viso Bumper with your name or logo.



## Technical data

Dimensions Viso Bumper  $\varnothing$  220 x 150 mm

Weight Viso Bumper 1 kg

Weight Viso Bumpert 10 G 1,2 kg

dial diameter  $\varnothing$  130 mm

Materials PE , Nylon , rubber , Aluminum

Manometer scale 0-300 mmHg

Suitable for circumferences

from 25,4 to 40,6 cm

**Viso Bumper yellow** **DG01600A**

**Viso Bumper black** **DG01601A**

**Viso Bumper yellow 10 G** **DG01602A**

**Viso Bumper black 10 G** **DG01603A**

# ANEROID SPHYGMOMANOMETER



## DGX 410/414/434

### ANEROID SPHYGMOMANOMETER

A small instrument that guarantees precision and reliability, essential in all first aid kits.

- Precision gauge
- Measuring system with two tubes
- Light alloy painted casing
- 0-300 mm Hg (DGX 410/434) or 0-200 mm Hg (DGX 414) scale
- Corrosion-free mechanism
- Floating zero
- Diameter of the internal dial 42 mm
- Regulation valve made of chromed metal
- Anti-allergenic nylon cuff calibrated with strap closure
- Zipper pouch
- Single packaging in cardboard box printed using a four-coloured process
- Weight DGX 410 344 g
- Weight DGX 414 312 g

**DGX 410 with adult cuff**

**DG01410C**

**DGX 414 with paediatric cuff**

**DG01414C**



## BAGS AND BACKPACKS

Bags and backpacks invented by designers of everyday items; those who every day tell us something, whispering their creation behind

our brand name, not residing in the design of design, but serving it with dedication and passion.

CLEAN AND PRECISE LINES, PERFECT STITCHING AND GEOMETRIC SHAPES THAT UN

DERLINE THE SIMPLICITY ARE THE CARDINAL POINTS OF SPENCER'S PRODUCTION.

The range of models and numerous finishings ensure an answer to meet the highest of expectations. Technological testing as well as

innovation in lines transmit extreme freedom of planning, that in these years has established endless records.

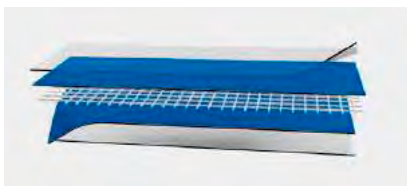

SPEN-TEX, a chemically processed material realised especially for medical bags.



### MATRIX

Matrix gives concrete form to a project, born from a spirit of exploration of the unknown both technologically and formally, creating objects exclusively for professionals. The modern plastic manufacturing techniques and the creativity of the designers have led to the realisation of bags, backpacks and cases for rescue missions, that have solved the dilemma between hard and soft materials. In fact, the Lycra thermally moulded polyethylene foam or polyester guarantee protection and lightness; the rounded shapes and corners improve the manoeuvrability and storage.

The technology employed allows for simple shapes, accurate details and the use of materials that render the product a high-quality item.

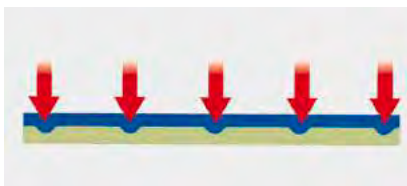

The use of Plastizote to stiffen and render the contents atraumatic.

## BAG MULTI-USE



### EMERGENCY EMERGENCY BAG

We have concentrated on the functionality of the product: a lightweight bag, easy to handle and easy to clean. Eliminating the superfluous, all you have left is the handiness of the product and the convenience of its price. Made of nylon, it has a central compartment where you will find on the inside a premodelled and semi-rigid compartment with three dividers to store a small oxygen tank and other resuscitation devices. The closure of the top flap is fast and safe thanks to the self-adherent strap all around the front border. There are also two side pockets with zipper.

Dimensions 525 x 215 x h230 mm

Weight empty 700 g

Weight complete 6 kg

Capacity 26 L

Emergency empty

CB08001A



### RESPONSE MULTI-USE EMERGENCY BAG

In the lower part of the soft bag, a series of elastic loops and a pocket that closes with self-adherent strips, allow for the placing of varied types of accessories.

On the fly-front opening of the upper part, there are elastic loops.

Dimensions 465 x 270 x h270 mm

Weight 1,2 kg

Capacity 34 L

Response red

CB07011A



### TOP 300 COMPACT RESUSCITATION BAG

- A compact bag, designed for resuscitation.
- A mesh bag with zip inside the upper flap
- Two lateral pockets with zips
- A frontal pocket with zip and internal elastic loops
- Semi-rigid, padded internal compartment, fixed with self-adherent strips
- Adjustable shoulder strap

Dimensions 450 x 180 x h225 mm

Weight 1 kg

Capacity 17 L

Top 300

CB09300B

## BACKPACKS



### A 911 RESCUE BACKPACKS SET

A 911 is a set of rescue backpacks extremely practical and versatile thanks to their compactness and lightness. The single backpack features a padded main compartment to ensure the safety of the content and has a reinforced structure to limit deformation. The bright colouring and reflective strips increase its visibility even in poor light conditions. Numerous internal and external pockets, allow an easier organization of the space for storing rescue equipment. The bottom is reinforced and non-slip as well as the carrying handle. The set includes six backpacks complete of five detachable internal pouches with zip closure and transparent top window.

Dimensions 490 x 220 x h490 mm

Weight 1,95 kg

External pockets 4

Internal bag 5 detachable with zip closure and transparent top

window

Portability carrying handle and padded shoulder straps

**A 911 six pcs CB00911A**

**A 911 complete BLS CB00913A**



### MARK PRO PROFESSIONAL EMERGENCY BACKPACK

Mark Pro is an extremely versatile product, made to suit the different requirements of all customers. Its structure allows it to suit all conditions and as well as its modern design that allows a rational use of the outside and inside space. It also has a rigid PVC structure that gives a unique advantage to its intrinsic strength and internal protection. Made in Cordura, it is completed with high visibility reflective bands and a reinforced PVC bottom part with protective rubber. Mark Pro can be used as a backpack or bag (the shoulder straps can be placed in a pocket with zip closure).

#### Mark Pro empty

Dimensions 360 x 300 x h550 mm

Weight Mark Pro 3,1 kg

Capacity 59 L

**Mark Pro yellow/black CB00450A**

#### Mark Pro with five M Series pouches

Dimensions 360 x 300 x h550 mm

Weight Mark Pro 4,9 kg

Capacity 59 L

**Mark Pro yellow/black CB00455A**

## BACKPACKS



### R-AID PRO

#### MULTI-PURPOSE EMERGENCY BACKPACK

R-aid Pro is a multi-purpose emergency backpack; extremely spacey and versatile, indicated for general emergency services. Developed in height, it can fit six different coloured pouches containing various emergency equipment and easy to placed with self-adherent strips.

The fixing system permits removal of any pouch from any position without interfering with the others. R-aid Pro includes also another two bags, removable by a zipper. The first is a small pouch on the top of the central part and the second a small but capacious backpack, attached to the front part. Both these two bags are attached with zips.

On the outside there are three pockets, two side ones and one in the back of the bag.

Anatomical back, adjustable and padded shoulder straps. Made in high resistant Cordura with reflective strips to improve visibility.

#### R-aid Pro with M Series pouches

Dimensions 400 x 300 x h600 mm

Weight R-aid Pro 4,45 kg

Capacity 45 L

R-aid Pro red/black

CB04500A

### R-AID TROLLEY PRO

#### MULTI-PURPOSE BACKPACK WITH TROLLEY

Extremely versatile and robust, R-aid Trolley Pro is a multi-purpose trolley usable also as a backpack. It is characterized by sturdy and affordable wheels, in order to ensure high load resistance, and by the possibility to be transported in four different ways thanks to the choice amongst carrying handles, shoulder strap, trolley system or shoulder straps.

Made of non-absorbent PVC

The M Series colourful pouches are available.

#### R-aid Trolley Pro empty

Dimensions 420 x 380 x h620 mm

Weight 3,3 kg

Capacity 51 L

R-aid Trolley Pro

CB04170B



## MISCELLANEA

Great topics for emergency medicine and first aid (like transfusions, medication and training), as well as the equipping of ambulances and personnel, become for Spencer the occasion to develop and handle technology that is capable of becoming leading in this field.

Basically, the consolidation of Spencer on the international markets is a

history of qualitative and technological records, in terms of materials, choice of construction and design, all obtained thanks to specific investments in research and development, consolidated in a production, without comparison, for range and service.



### THE CHROMATIC RESEARCH

Although functionality is the central value of an instrument, when talking about style and technology one cannot overlook the importance of colour. The capacity to distinguish,

individualize, follow and identify an object, its properties and the function for which it has been designed, are just some of the requirements of the system of perception, necessary



to enable an adequate behavioural control. The new collection, Match 3, expresses itself with a defined and unmistakable style, a union created between shape and colour.

### HYPOTHERMIA

Spencer a firm and a brand label that has, right from the outset, made challenges a way of working and of life.

Right from the outset, when the pre-hospital, preventive treatment of hypothermia was provided only by the use sheets of metallic plastic, Spencer studied more effective and

efficient techniques for the insulation and heating of intravenous solutions.



A professional and portable working system used to both protect and heat two intravenous bottles or bags, thanks to the use of an electrical resistance.



An indispensable active system for ambulances for warming intravenous bottles, thanks to the use of instant heat, but also an anti-oscillation and protective device for the bottles themselves.



An active but economical system to warm, with the use of instant heat, the intravenous solution contained in the bags, but also a strong container for the protection of the bags themselves.

# WATER RESCUE



## Technical data

Dimensions 170 x 80 x h1200 mm  
Weight 2 kg  
PU material body expanded  
Material belts Polyester  
Color yellow  
Flex Mask color blue box  
Latex Free

### DOLPHIN

#### UNIVERSAL LINEAR LIFESAVER

Made of closed-cell, self-filling polyurethane foam, it has a higher flexibility and resistance than any other type of rescue tube, therefore able to adapt to rescue victims of any size. Dolphin has three separate but at the same time fundamental functions: it can be wrapped around the casualty for rescue and sea recovery; it provides emergency resuscitation thanks to the Flex Mask stored in its own housing on the device and last but not least it also has a space for fin storage. The design studies have led to the development of a wave-shaped form, which ensures a firm grip, easy to bend and the redistribution of weight, correctly balanced to assist superior range high performance throwing.

**Dolphin with Flex Mask and handles**

**DY32500D**

## Technical data

Dimensions 655 x 235 x 120 mm  
Rope length 2820 mm  
Shoulder strap width 50 mm  
Shoulder strap circumference (not adjustable) 690 mm  
Materials PE, PP  
Floating body weight 1,2 kg  
Overall Weight 1,36 kg  
Maximum buoyancy force 65 N if completely submerged



### LIFE GUARD

#### PROFESSIONAL LIFE-SAVING BUOY

A tapered life-saving device; pointed at the front, in rigid plastic equipped with handles on the sides and at the back.

Made in medium density polyethylene without seams, it guarantees good buoyancy and is hydrodynamic.

The method used in moulding renders it robust and therefore usable also for rescue operations and special recoveries; it is ideal for beach patrols and irreplaceable in multiple and scuba diver rescues. A rot-proof shoulder strap in polypropylene and its floating top make Life Guard a very suitable buoy for the professional water rescuers.

**Life Guard orange**

**SR10000A**

## CONTAINER FOR USED NEEDLES AND KNEE-PADS



### PRO SPIKE

#### COMPACT CONTAINER FOR USED NEEDLES

Pro Spike is a small disposable container; it allows separate collection of all spiky and cutting wastes (needles, scalpels) on the operation field. Made for the rescuer's safety, small sized, Pro Spike is always ready for use. It has a clever lid with a safe closing system and a clip so you can attach it to belts, backpacks and other things.

Made of plastic material, it can be disposed of with the contents.

Dimensions 90 x 54 x h185 mm

Weight 88 g

Material polyethylene

**Pro Spike box 5 pcs**

**FG04591C**



### PR 50

#### ANTI-SLIP EVA KNEE-PADS

Very thick, with semi-rigid body distinguished by an exceptional elastic memory.

Realised in high-density closed cell heat formed foam, protected by a special film in polypropylene. The upper part of the knee-pad is cambered anatomically to confer a comfortable posture and a strong structure. The uniform thickness confers to the knee-pad an elasticity and protection adequate to the load. The closings are supplied by two bands of elastic with self-adherent strips application, that guarantee a firm posterior closing and correct regulation.

Weight 158 g

**PR 50**

**DR20050B**

## PROFESSIONAL BURN KIT



### MAXI BURN KIT

#### PROFESSIONAL BURN KIT

A must kit for all rescue units. It contains all necessities to treat a burn patient. The new Matrix bag protects all the contents and finds a space in all vehicles.

The used materials can be replaced with spare parts.

#### Maxi Burn Kit contains

- Universal scissors 10 x 10 cm
  - One pack of sterile gloves
  - Two Burn S dressings 10 x 10 cm
  - One Burn S dressing 20 x 20 cm
  - One Burn S dressing 55 x 40 cm
  - Ten Burn B gel packs 3,5 ml
  - One self-adhesive bandage
  - One sterile gauze pad
  - Two isothermal blankets
  - Two instant ice in bags
- Dimensions 340 x 90 x h300 mm  
Weight 2,2 kg
- Maxi Burn Kit BS05006B**



### STX 641

#### FIREPROOF BLANKET

Made in fibreglass and treated with silicone, it is hemmed and has two tapes to render the grip more secure.

#### Characteristics

- Extinguishes the flames promptly and lowers the heat level of the burnt part by completely isolating from the heat
  - Very robust and resistant to traction
  - Particularly suitable for victims whose clothes have caught fire
  - Ideal for putting out small fires or fires where the use of an extinguisher proves difficult, to protect oneself while escaping from fire
  - or whilst in vehicles
  - Conforms to the EN 1869/97 regulations, the fibreglass fire-proof blanket does not burn, does not leave deposits and is non-toxic
- Supplied with a soft holder or a rigid container.  
Dim. STX 640 1200 x 1800 mm  
Dim. STX 641 1200 x 1200 mm
- STX 641 with soft holder ST00641B**



## MISCELLANEA



### FORCE KIT

#### FORCED ENTRY KIT

Spencer the leader in resolving problems for first responders and rescuers, presents a new collection of multi-functional kits for extrication and forced entry contained in the Force Bag. Expert hands have created this bag, at a restrained price, in tear-proof nylon Ripstop. Force Bag is extremely functional and characterized by a resistant structure and professional look. In fact the body is made in a techno polymer mould that is able to carry heavy tools and accessories.

#### Force Kit 1

Contains STX 644, GDX 001, GDX 002, GDX 003, GDX 004, GDX 005, TTX 199.

Dimensions 275 x 130 x h490 mm

Weight 6,1 kg

Force Kit 1

GD04000B



### MATCH 3

#### MULTI-PURPOSE SCISSORS

Match 3 is born, a compact multi-purpose scissors, realized to satisfy the request of an easy and efficient tool.

High versatility of use for excellent performance on different materials when cutting or breaking. Thanks to the use of special steel and experienced handcrafted building techniques, this tool guarantees durability and high precision cutting. Thanks to its plastic support it can be easily fixed to walls or by using the springs provided it can be attached to the upholstery of any type of vehicle: ambulance, helicopter, Civil Defense vehicles, Fire Brigades trucks, Police cars, public transportation vehicles.

Length 245 mm

Weight 390 g

Match 3 chrome with black handle

GD02060C



**HT**

### ISOTHERMAL SHEET

Indispensable device in the first aid of traumatised and burnt patients. Provides protection from the cold with the silver part towards the body: it reflects the heat of the body and avoids hypothermia.

Allows protection from the heat if the gold part of the sheet is next to the body: the sun rays are reflected allowing the body to remain fresh.

Made of aluminiumised polystyrene sheets.

Single packaging in individual packet.

Dimensions adult 2200 x 1600 mm

Dimensions of the packet 175 x 93 mm

**HT adult box 20 pcs**

**ST00633A**



**HM**

### ISOTHERMAL BLANKET

The HM blanket is very lightweight, insulating and isothermal and being very robust it can be used more than once. The generous use of aluminium and the internal reinforcement ensure the following qualities: resistance to wind, waterproofness, light weight.

Provides protection from the cold with the silver part touching the body: it reflects the heat of the body and avoids hypothermia.

The HM isothermal blanket can be used even in extreme temperatures.

Dimensions 2000 x 1400 mm

Weight 646 g

**HM**

**ST00610C**



**SPENCER INDIA TECHNOLOGIES PVT. LTD**  
**PLOT No. 477, GROUND FLOOR, SECTOR 26, BHARTHAL,**  
**110077 | DWARKA | NEW DELHI | INDIA**  
**Mobile: +91-99715 86305**  
**Email: [info@spencer-india.com](mailto:info@spencer-india.com)**

SPT16888 Rev.0.05/08/2021

Visit our website [www.spencer-india.com](http://www.spencer-india.com)



Follow us

